

Load Curves

	13.2	14	15	16	17	18	19	20	22	25	27	30	32	35	37	40	m
40m	4000	3700	3400	3150	2950	2750	2550	2400	2150	1800	1650	1450	1350	1200	1100	1000	kg
Full 40m jib folded out																	
	15.7	16	17	18	19	20	22	25	27.4	m							
27.4m	4000	3900	3650	3400	3200	3000	2650	2300	2050	kg							
12.6m jib section removed reducing maximum jib length to 27.4m																	
	13.9	14	15	16	17	18	19	20	22	25	27	28	m				
28m	4000	3950	3650	3350	3150	2900	2750	2550	2300	1950	1800	1700	kg				
12m jib section hydraulically folded back to reduce jib length to 28m																	

Erection Schematic

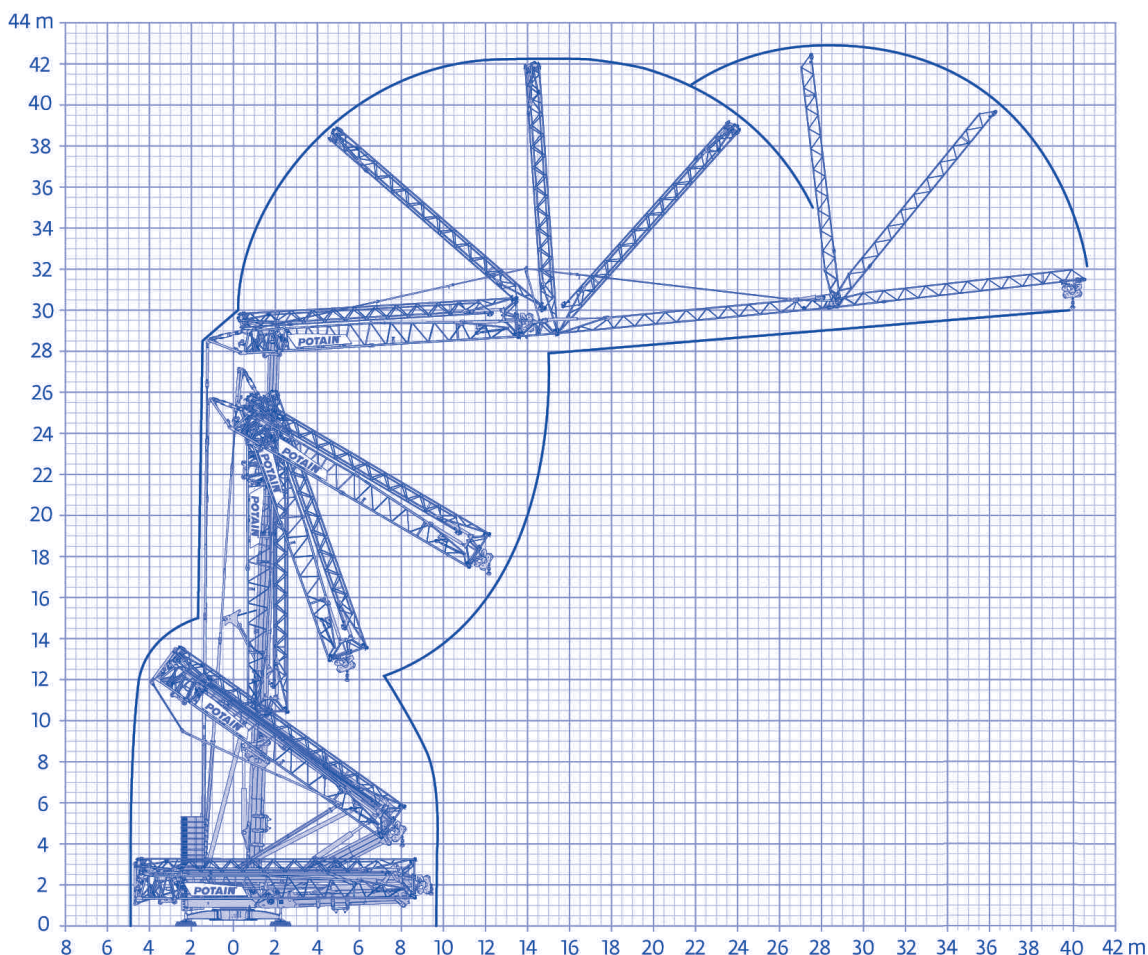

Mode of Transport

Suitable Low Loader Trailer

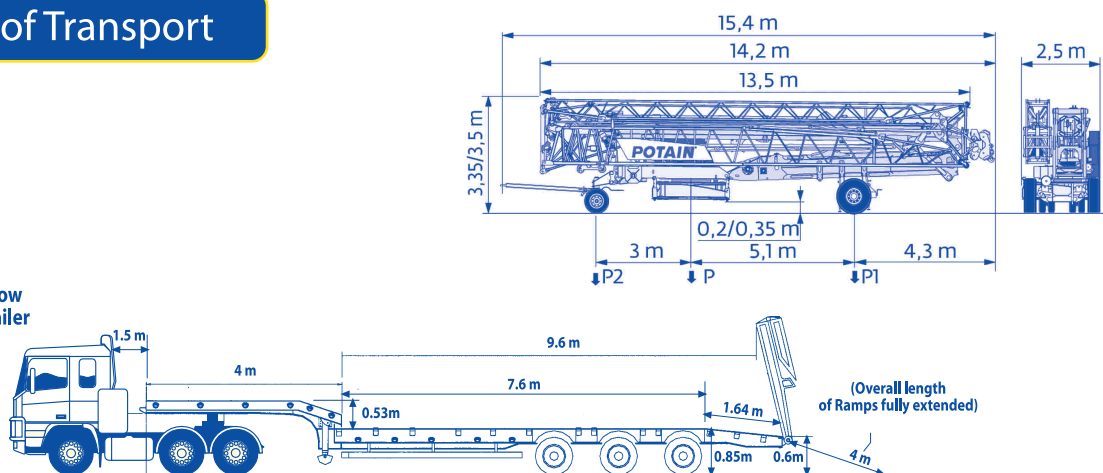

Weights

Dead Weight without Transport Axles & Permanent Ballast	15,000 Kg
Dead Weight with Transport Axles & 5,640kg Permanent Ballast	21,655 Kg

Ballast Weights @ 30m (full height)	
15 No @ 1,750kg	26,250kg
1 No. @ 870kg	870kg
Total	27,120kg

Ballast Weights @ 25.6m (full height)	
14 no @ 1,750kg	24,500kg
Total	24,500kg

The technical information contained in this document is useful as a basic introduction to the crane. In no case may this document serve as a substitute for the various manuals bearing the machine number of the crane.