

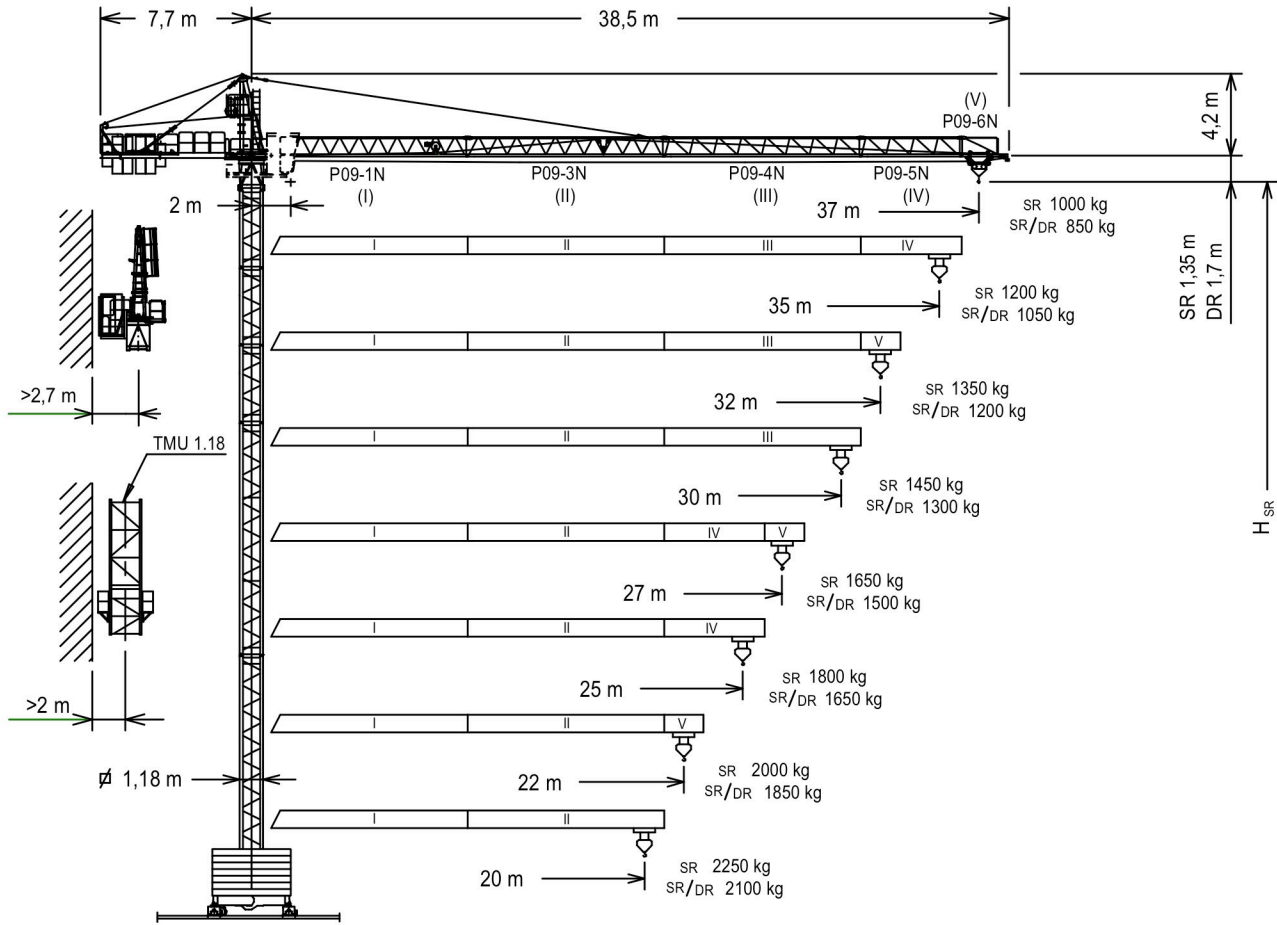

EN 14439
C25

UNE-EN-ISO 9001



$H_{DR} = H_{SR} - 0,35$

Altura máxima bajo gancho sin arriostrar (m).
Maximum height under hook without fastening (m).

Hauteur maximale sous crochet sans ancrage (m).

Максимальная высота под крюком без крепления (m).

Bağlantısız maksimum kanca altı yüksekliği (m).

أقصى ارتفاع تحت الخطاف بدون ربط (m)



$H_{SR} = 2$ m.

P09-1N	149.40.500
P09-3N	149.42.000
P09-4N	149.43.000
P09-5N	149.44.000
P09-6N	149.45.000
TR 12	146.30.000
T 12	126.21.500
TR 8RM	202.30.000
TR 8M	146.30.800
TR 4	800.32.300
T 4	126.32.000
TN 2	146.32.500

BTX 45/BEX 45	137.20.500
BTX 38R/BEX 38R	137.20.000
BTX 38/BEX 38	149.20.000
BTX 28/BEX 28	149.20.500
ABH 90	146.23.000
ABH 75	152.23.000
AR 12	137.21.000
AN 12	146.21.000
BE 442	146.24.850
BE 434	146.24.950
TMU 1.18	202.35.500

(H) TRASLACIÓN / TRAVELLING /

TRASLATION / ПЕРЕМЕЩЕНИЕ / RAY YÜRÜYÜŞLÜ / متحركة

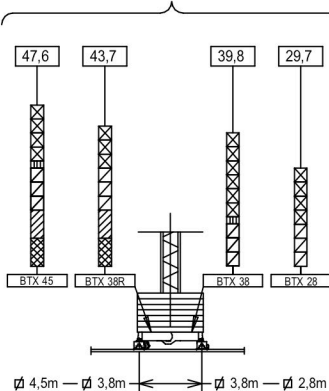

(H) ESTACIONARIA / STATIONARY /

STATIONAIRE / СТАЦИОНАРНОЕ СОСТОЯНИЕ / SABIT / ثابتة

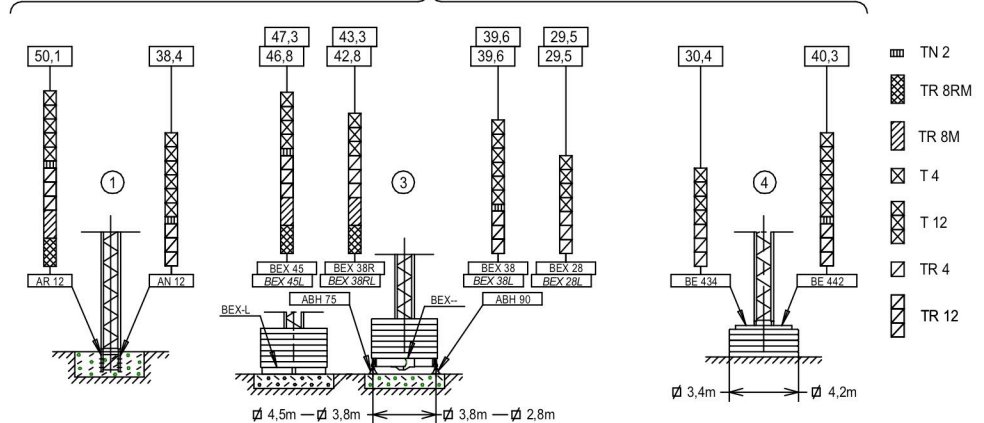

Fecha / Date: 28/04/2020



FEM 1005 - C25

Reservado el derecho a modificaciones sin previo aviso. Declinamos toda responsabilidad derivada de la información proporcionada / Subject to modification, without previous warning. This information is supplied without liability / L'entreprise se réserve le droit de procéder à des modifications sans préavis. Nous déclinons toute responsabilité quant aux informations fournies / Мы оставляем за собой право на внесение изменений без предварительного уведомления. Мы снимаем с себя любую ответственность в отношении предоставленной информации / Onceden bildirilmeksizin değiştirilme hakkı saklıdır. Verilen bilgiler için hiçbir sorumluluk kabul etmemekteyiz

Cargas máximas / Maximum loads / Charges maximales / Максимальные нагрузки / Maksimum yük / أقصى حمولة		SR1-2 t								
SR1 (t)	Alcance del gancho [m] / Hook reach [m] / Portée du crochet (m) / Радиус действия крюка (m) / Kancanın yüksekliği (m) / مدى الخطاف	20	22	25	27	30	32	35	37	
2 t @...[m]										
37 m	20,2	2	1,82	1,57	1,45	1,27	1,20	1,07	1	
35 m	22,3	2	2	1,76	1,62	1,43	1,33	1,20	---	
32 m	22,6	2	2	1,77	1,63	1,45	1,35	---	---	
30 m	22,5	2	2	1,78	1,64	1,45	---	---	---	
27 m	22,7	2	2	1,79	1,65	---	---	---	---	
25 m	22,7	2	2	1,80	---	---	---	---	---	
22 m	22,0	2	2	---	---	---	---	---	---	
20 m	20,0	2	---	---	---	---	---	---	---	

Cargas máximas / Maximum loads / Charges maximales / Максимальные нагрузки / Maksimum yük / أقصى حمولة		SR2-2,5								
SR2 (t)	Alcance del gancho [m] / Hook reach [m] / Portée du crochet (m) / Радиус действия крюка (m) / Kancanın yüksekliği (m) / مدى الخطاف	15	20	22	25	27	30	32	35	37
2,5 t @...[m]										
37 m	16,5	2,5	2,03	1,82	1,57	1,45	1,27	1,20	1,07	1
35 m	18,2	2,5	2,25	2,03	1,76	1,62	1,43	1,33	1,20	---
32 m	18,4	2,5	2,28	2,05	1,77	1,63	1,45	1,35	---	---
30 m	18,4	2,5	2,28	2,05	1,78	1,64	1,45	---	---	---
27 m	18,5	2,5	2,30	2,07	1,79	1,65	---	---	---	---
25 m	18,5	2,5	2,30	2,07	1,80	---	---	---	---	---
22 m	17,9	2,5	2,22	2	---	---	---	---	---	---
20 m	18,2	2,5	2,25	---	---	---	---	---	---	---

Cargas máximas / Maximum loads / Charges maximales / Максимальные нагрузки / Maksimum yük / أقصى حمولة		SR/DR-2 t / 4 t									
SR/DR (t)	Alcance del gancho [m] / Hook reach [m] / Portée du crochet (m) / Радиус действия крюка (m) / Kancanın yüksekliği (m) / مدى الخطاف	10	15	20	22	25	27	30	32	35	37
2 t / 4 t @...[m]											
37 m	19,0/10,3	2/4	2/2,62	1,87	1,67	1,42	1,30	1,12	1,05	0,92	0,85
35 m	20,9/11,3	2/4	2/2,92	2/2,1	1,87	1,62	1,47	1,27	1,17	1,05	---
32 m	21,1/11,4	2/4	2/2,97	2/2,15	1,9	1,65	1,50	1,30	1,20	---	---
30 m	21,1/11,4	2/4	2/2,97	2/2,12	1,9	1,62	1,47	1,30	---	---	---
27 m	21,3/11,5	2/4	2/3	2/2,15	1,92	1,65	1,5	---	---	---	---
25 m	21,3/11,5	2/4	2/3	2/2,15	1,92	1,65	---	---	---	---	---
22 m	20,6/11,1	2/4	2/2,87	2/2,07	1,85	---	---	---	---	---	---
20 m	20,0/11,3	2/4	2/2,92	2/2,1	---	---	---	---	---	---	---

CARACTERÍSTICAS DE MECANISMOS / MECHANISMS FEATURES / CARACTÉRISTIQUES DES

MÉCANISMES / ХАРАКТЕРИСТИКИ МЕХАНИЗМОВ / MEKANİZMLARIN ÖZELLİKLERİ / الخصائص الآلية		EC1846 SR2 13,2 kW				EC1856 SR1 13,2 kW			*EC2566 SR2 18,4 kW			*EC2580 SR1 18,4 kW			TG825VF 2x3 kW	OG408VF 3 kW	TC360 / *TC360VF 1,9 / *1,8 kW	TH1010 9,2 kW	
opcional / optional / en option / опция / opsiyonel / اختياري																			
t	m/min	1,3	2,5	2,5	1,1	2	2	1,3	2,5	2,5	1,1	2	2	0...25	0...0,8	30/60	*0...30	1	
		46	23	5	56	28	6	64	32	8	82	41	10		r/min	m/min	*30...60	m/min	
t	m/min													400V 50Hz P_{TOTAL} (EC1846/EC1856 + OG408VF + TC360) = 18,1 kW P_{TOTAL} (*EC2566/*EC2580 + OG408VF + *TC360VF) = *23,2 kW EC1846 / EC1856 / TC360 kW +20% *EC2566/*EC2580 / TH1010 m/min +20%					
H		H ≤ SR 193 m			DR 96,5 m			SR 189 m			DR 94,5 m								

LASTRES INFERIORES / LOWER BALLASTS / LESTS INFÉRIEURS / НИЖНИЙ БАЛЛАСТ / ALT AĞIRLIK TAŞLARI / ثقُل

H (m)		18	22	28	32	36	40	44	47,6	
BEX 45 / BTX 45 BEX45L BEX 38R / BTX 38R BEX 38 / BTX 38 BEX 38RL / BEX 38L	4100 kg	4		6		8	10	12	14	
		4		6		8	10	12	14	
		4		6		8	10	12	14	
		4		6		8	10	12	14	
BEX 28 / BTX 28	3700 kg	6	8	10	-----					
H (m)		18,3				30,4				
BE 434	4300 kg	8				10				
H (m)		26,1			30			40,3		
BE 442	3450 kg	12		16			20			

H: Altura bajo gancho / Height under hook / Hauteur maximale sous crochet Высота под крюком / Kanca alti yüksekliği / الارتفاع أسفل الخطاف

Para alturas intermedias tomar el lastre correspondiente a la altura superior / For intermediate heights take the ballast corresponding to the higher height / Pour les hauteurs intermédiaires, opter pour le lest correspondant à la hauteur immédiatement supérieure / Для промежуточных высот возьмите балласт, соответствующий большей высоте / Orta yükseklikler için daha üst bir yüksekliğe karşılık gelen ağırlığı alıniz. / لارتفاعات البينية يرجى استخدام الثقل العائد للارتفاع الأعلى /



Fecha / Date: 28/04/2020

FEM 1005 - C25

Reservado el derecho a modificaciones sin previo aviso. Declinamos toda responsabilidad derivada de la información proporcionada / Subject to modification, without previous warning. This information is supplied without liability / L'entreprise se réserve le droit de procéder à des modifications sans préavis. Nous déclinons toute responsabilité quant aux informations fournies / Мы оставляем за собой право на внесение изменений без предварительного уведомления. Мы снимаем с себя любую ответственность в отношении предоставленной информации / Önceden bildirilimsizin değiştirilme hakkı saklıdır. Verilen bilgiler için hiçbir sorumluluk kabul etmemekteyiz / حقوق التغيير محفوظة دون إشعار مسبق. دون أدنى مسؤولية عن المعلومات المقدمة

LISTA DE EMBARQUE / PACKING LIST /

J37NS

LISTE DE COLISAGE / СПИСОК ПОСТАВКИ / ÇEKİ LİSTESİ / قائمة التحميل

DENOMINACIÓN / DENOMINATION / DÉSIGNATION / НАЗВАНИЕ / İSİMLENDİRME / اسم	L [m]	A [m]	H [m]	P / W [kg]			
Torre Tower Tour Башня Kule برج	TR 8RM – TR 8M TR 12 – T 12 TN 4RA – T4 TR 4 TN 2			8,07 12,01 4,06-4,09 3,96 2,29	1,19 1,19-1,18 1,19-1,18 1,18 1,19	1,19 1,19-1,18 1,19-1,18 1,18 1,19	2575-2515 2840-2025 1100-795 1070 785
Conjunto asiento pista, punta de torre y orientación Slewing table assembly, tower head and slewing mechanism Groupe pivot + porte-flèche + mécanisme d'orientation Сиденье площадки + верхняя секция башни + поворотный механизм Göbek + kulenin kafa bölümü + mekanizma مجموعة وحدة الدوارن + رأس البرج + آلية الدوران				2,85	1,61	2,15	1860
Estructura punta de torre + Elevación Tower head structure + hoisting Structure porte-flèche + mécanisme de levage Структура верхней секции башни + подъемный механизм Kule kafa bölümü yapısı+vinç kulesi هيكل رأس البرج + آلية الرفع				4,45	1,19	2,31	1640
Torre asiento pista + punta de torre + orientación + elevación Slewing table + tower head + slewing + hoisting mechanism Tour pivot + base du porte-flèche + mécanisme d'orientation Сиденье площадки + основание верхней секции башни + поворотный механизм Döner tabla+kule kafa bölümü tabanı+mekanizma برج وحدة الدوارن + قاعدة رأس البرج + الدوران + الرفع				5,96	1,61	2,40	3500
Tramo de pluma Jib section Tronçon de flèche Секция стрелы Vom bölümü أجزاء الذراع	P09 1N (I) P09 3N (II) P09 4N (III) P09 5N (IV) P09-6N (V)			10,13 10,15 10,15 5,26 2,13	1 0,87 0,87 0,87 0,86	1,13 1,12 1,03 1,02 1,02	1020 880 575 295 110
Polipasto / Hook assembly / Palan / Полуспаст / Kanca takımı / بكرة	SR DR			0,76 0,76	0,16 0,20	0,96 1,40	135 155
Carro / Trolley / Chariot / Грузовая тележка / Şaryo / عربة	SR DR			1,00 1,04	1,33 1,37	0,73 0,88	110 175
Contrapluma con plataformas / Counterjib with platforms Contre-flèche avec plateformes / Противовесная консоль с платформами / Platformlu kuyruk / المنصة مع المقابل الذراع				6,75	1,41	0,43	1200
Plataforma y cabina / Platform and cabin / Plateforme et cabine Платформа и кабина / Platform ve kabine / منصة وكابينة				3,69	1,63	2,25	820
Contrapeso / Counterweight / Contrepoids / Противовес / Denge ağırlığı / اوزان معاكسة	Grande / Big / Grand / Большой / Büyük / كبير Pequeño / Small / Petit / Малый / Küçük / صغير			1,08 1,08	0,50 0,50	2,02 1,30	2360 1500
Base grúa Testero largo Crane base Long carriage Base de la grue. Palonnier long Основание крана. Длинная передняя часть Vinç tabanı. Uzun vinç arabası قاعدة الرافعة مقدمة طويلة (للكابينة)	BEX 28 BEX 38 BEX 38R BEX 45 BTX 28 BTX 38 BTX 38R BTX 45			4,96 6,38 6,38 7,37 4,60 6,02 6,02 7,01	0,84 0,84 0,84 0,84 1,62 1,62 1,73 1,62	1,53 1,53 1,47 1,47 1,63 1,63 1,73 1,73	2870 3400 3800 4380 4005 4760 5230 5995
Lastre / Ballast / Lest / Балласт / Alt ağırlık taşları / ثقلي	☑ 2,8m ☑ 3,8m - ☑4,5m BE 442 BE 434			3,00 4,00 2,09 3,40	0,44 0,34 0,34 0,34	1,30 1,30 2,10 1,69	3700 4100 3450 4300
Torre de montaje / Jacking cage / Tour de montage / Монтажная башня / Kaldırma kafesi / برج التركيب				7,14	1,76	1,71	3200
Torre de montaje sin puerta, carro, plataforma carro y viga de apoyo Jacking cage without door, trolley, trolley platform and beam assembly Tour de montage sans porte, chariot, plateforme de chariot et poutre de soutien Монтажная башня без двери, грузовой тележки, платформы грузовой тележки и опорной балки Kapısız kaldırma kafesi, vinç köprüsü arabası, vinç köprüsü arabası platformu ve giriş takımı برج التركيب بدون بوابة ، وعربة ومنصة متحركة وعارضة تدعيم				7,14	1,76	1,71	2450



Fecha / Date: 28/04/2020

Reservado el derecho a modificaciones sin previo aviso. Declinamos toda responsabilidad derivada de la información proporcionada / Subject to modification, without previous warning. This information is supplied without liability / L'entreprise se réserve le droit de procéder à des modifications sans préavis. Nous déclinons toute responsabilité quant aux informations fournies / Мы оставляем за собой право на внесение изменений без предварительного уведомления. Мы снимаем с себя любую ответственность в отношении предоставленной информации / Önceden bildirilmesizin değiştirilme hakkı saklıdır. Verilen bilgiler için hiçbir sorumluluk kabul etmemekteyiz

FEM 1005 - C25

T	H							H	T	
1	4,5	T 4 126.32.000	T 4	T 4	T 4	4,5	1	T 4	4,5	1
2	8,4					8,4	2		8,4	2
3	12,4	T 12	T 12	T 12		20,3	3	T 12 126.31.500	20,3	3
4	24,3	TR 12	TR 12	TR 12		32,2	4	TR 12 146.30.000	32,2	4
5	36,2	TR 8M	TR 8M	TR 8M		40,1	5	TR 8M 146.30.800	40,1	5
6	44	TX-90 / TXXR T 3-90	TX-90 / TXXR T 3-90	TX-90 / TXXR T 3-90		43,9	6	TX-90 / TXXR 202.36.500 T 3-90 133.32.000	43,9	6
7		AR 12				46,8	7		46,8	7
8	49,7			T6-150A		52,6	8	T6-150A	52,6	8
9	52,7	AN 90		TL20 / Tx 150 161.31.300		56,5	9	TL20 / Tx 150 161.36.000	56,5	9
10	61,4			T6-150 161.31.000		62,1	10	TL20-5,6 204.31.400	62,1	10
11				AN 150		67,7	11	TS20-5,6A 204.31.500	67,7	11
				AL20				TS20-5,6 204.31.500	70,4	12
				AS 20				TSR20-5,6A 204.31.300	78,9	13
								TSR20-5,6 204.31.000	84,5	14
								ASR 20		

AR 12 137.21.000
ARD 12 137.21.800
AN 90 133.21.000
AND 90 133.21.800
AN 150 161.21.000 AS 20 160.21.010
AND 150 161.21.050 ASD 20/24 160.21.080
AL 20 153.21.800 ASR 20 160.21.200
ALD 20 160.21.250 ASRD 20/24 156.21.000

T: Torre / Tower / Tour / Башни / Kuleler / أبراج
H: Altura / Height / Hauteur / Высота / Yükseklik / ارتفاع

Otras configuraciones de torre / Other tower configuration / Autres configurations / Прочие конфигурации / Diğer konfigürasyonlar / مكونات أخرى

Transporte / Transport / **Transportation / Taşıma / نقل**

H=38,4 + AN12

2x

3x **HIGH CUBE 40'**

≤ 6xT4

$h_{max} = 3 \times TR4 + 6 \times T4$

h (m)	36
D (m)	8 - 10
P (KN)	403 / 378
Rmax (KN)	90 / 249

TR4: 800.32.300

Trepado interno / Internal climbing. / **Télescopage intérieur / Внутренняя лестница / Bina içi tırmanma / التسلق الداخلي**

Viento fuera de servicio / Out of service wind / Vitesse du vent hors service / Ветровая нагрузка в покое / Rüzgar devre dışı / **الرياح خارج الخدمة**

- Consultar / Consult / Nous consulter / Консультируйтесь / Danışınız / الرجوع إلى
- En servicio / In service / En service / В работе / Devrede / **في الخدمة**
- Fuera de servicio / Out of service / Hors service / В покое / Devre dışı / **خارج الخدمة**



GSM : +33(0)6 11 16 84 14

E-mail : contact@locetmat.com
Web Site : www.locetmat.com

LOC & MAT

Tel : +33(0)4 68 92 50 92

FEM 1005 - C25

Reservado el derecho a modificaciones sin previo aviso. Declinamos toda responsabilidad derivada de la información proporcionada / Subject to modification, without previous warning. This information is supplied without liability / L'entreprise se réserve le droit de procéder à des modifications sans préavis. Nous déclinons toute responsabilité quant aux informations fournies / Мы оставляем за собой право на внесение изменений без предварительного уведомления. Мы снимаем с себя любую ответственность в отношении предоставленной информации / Önceden bildirilmeksizin değiştirilme hakkı saklıdır. Verilen bilgiler için hiçbir sorumluluk kabul etmemekteyiz /

حقوق التغيير محفوظة دون إشعار مسبق دون أدنى مسؤولية عن المعلومات المقدمة