

Sáez motion

SÁEZ

machinery



SZ306



The SZ306 telescopic handler is an all-terrain handler machine that is compact, manoeuvrable, powerful and precise.

It is **compact** due to its reduced dimensions of 2000 mm high by 2000 mm wide, which make it suitable for work anywhere.

It is **manoeuvrable** due to its excellent turning radius of 3100 mm, which makes it an ideal machine for small spaces. Furthermore, it has three types of directional movement, forwards, concentric and sideways in order to adapt to the needs of the environment.

It is **all-terrain** thanks to its permanent all-wheel drive with 75% self-locking differential, which allows for maximum grip in any situation, and for the machine to transmit all of its power to the ground through its 405/70-20 tyres that are specifically designed for difficult and aggressive terrain.



It is **powerful** because of its Perkins 70Kw combustion engine and its torque of 392Nm, which supplies power to its Bosch-Rexroth hydrostatic travel drive and to its Parker operating pump. All of this makes it possible to load up to 3 tons, and lift them 6 metres high, with 2 speeds.

It is **precise** due to its Inching-Control system that makes even the most delicate operation a simple task.

The SZ306 model has been designed to maximise ease of maintenance and reduce the cost of maintenance, as it provides full accessibility to all of the parts that require maintenance, whether on a periodical basis, or with breakdowns, thus minimising the time invested in any repair.

It is also necessary to make a special mention of how it respects the environment, by incorporating a combustion engine that is adapted to the TIER III standard for the emission of gases and incorporating Load-Sensing technology in the hydraulic movement system, which detects the load that the circuit is subjected to and changes the energy flow by adapting it automatically to the demands of the work, thereby preventing the waste of energy.

A lot of care has also been taken with the SZ306 in relation to the safety and comfort of the operator. Its spacious cabin has great visibility and is equipped with ergonomic controls, a joystick with proportional functions and it is approved by FOPS/ROPS standards.



Equipment

- Engine Perkins 70Kw Tier III/sTAGE IIIA
- Four-wheel drive and guidelines
- Dual air filter
- Fuel filter with water separator
- Hydrostatic filter
- Hydraulic return filter
- Safety valves on cylinders
- Hydrostatic pump and motor with variable displacement
- Service pump Load Sensing
- Electro-proportional control movements
- Inching hydrostatic disconnection
- Hydraulic auxiliary system in boom and rear
- Negative brake for differential lock
- Stability control device visual and acoustic
- Cabin according FOPS/ROPS with heated and ventilated
- Protection grid cabin roof
- Right and left door mirrors
- Adjustable seat with seat belt
- Adjustable steering column
- Joystick with propositional functions
- Hydraulic power steering
- Oil filter status indicator visual services
- Rear axle alignment indicator
- Door with two pieces hinged opening 180°
- Horn
- Hourmeter
- Prewired radio and speakers
- Rotating light
- Mudguard
- Forks with sideshift
- Road light front and rear
- Tires 405/70-20
- Working lights front and rear
- 7-pin electrical connector



Tecnical Data

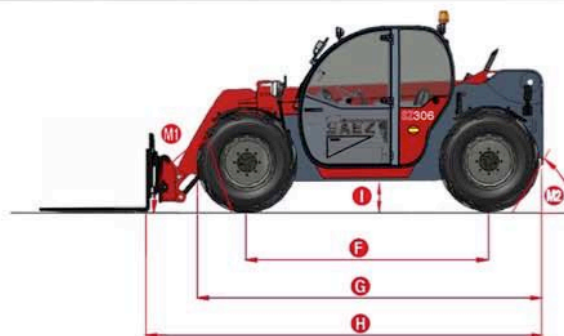
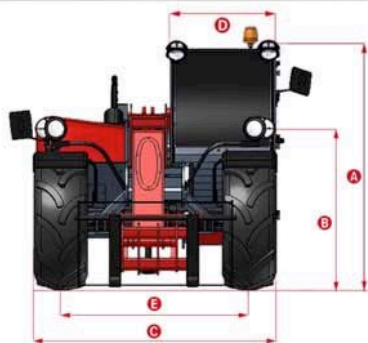

MODEL SZ-306

MEASUREMENTS

Height	6,00 m
Maximum lift capacity	3.000 kg
Lift capacity at maximum height	3.000 kg
Lift capacity at maximum reach	1.500 kg
Maximum reach	3,10 m
Maximum reach at maximum height	0,6 m
A Overall height	1,97 m
B Height to steering wheel	1,24 m
C Width	1,99 m
D Width cabin	0,89 m
E Front track	1,58 m
F Wheelbase	2,69 m
G Overall lenght to front of tires	3,82 m
H Overall lenght to front of carriage	4,31 m
I Ground clearance	0,3 m
M1 Entry angle	70°
M2 Departure angle	59°

FEATURES

Turn radius wheel int./ext.	1,38 m/3,37 m
Penetrating power (bucket 800l SAE J 732/80)	3.500 kg
Tractive effort	4.540 kg
Speed in travelling mode (max.)	30 km/h
Carriage rotation	131°
Tyres	405/70 20" PR14

ENGINE AND TRANSMISSION

Engine	Perkins, diesel, 70 Kw, Stage IIIA
Transmission	Hidrostatic motor-pump
Hydraulic pump	Gear pump 250 bar, 82 l/min
Fuel tank	90 L
Engine oil	8.5 L
Hydraulic tank	100 L

WEIGHT

Weight unladen (without forks)	5.635 kg
--------------------------------	----------



Lift performance

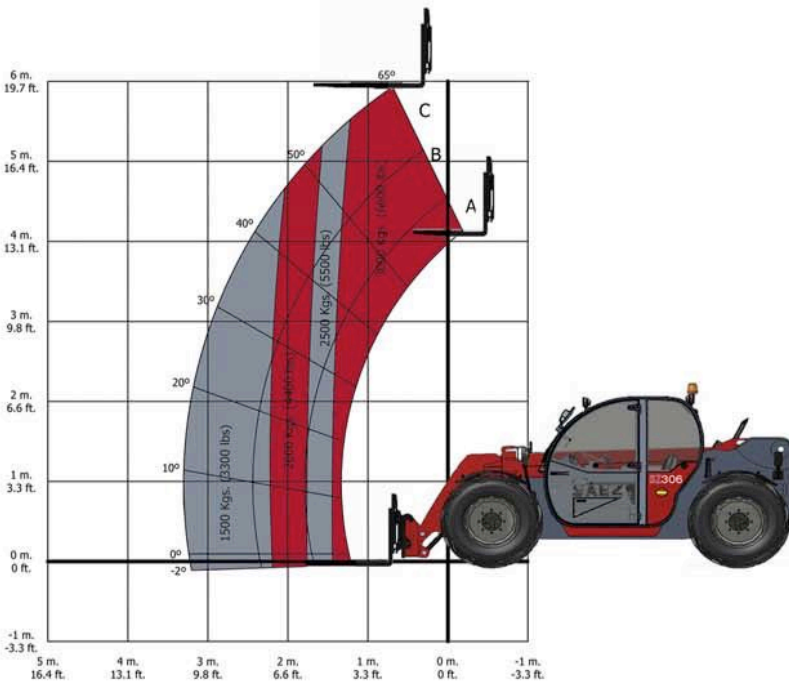

Maximum lift capacity	3,000 kg	6,613 lbs
Height lift capacity	6,000 mm	19 ft 7 in
Maximum reach	3,100 mm	10 ft 2 in
Height at maximum load	6,000 mm	19 ft 7 in
Reach at maximum load	1,400 mm	4 ft 6 in
Lift capacity at maximum height	3,000 kg	6,613 lbs
Lift capacity at maximum reach	1,500 kg	3,307 lbs



Attachments

Forks with sideshift



Jibs of various types and capabilities



Bucket of various types and capabilities

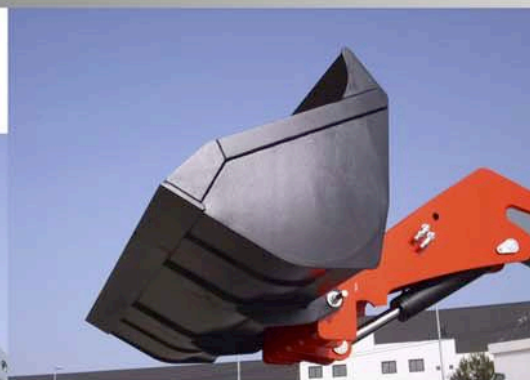

There are a variety of accommodations and types of attachments that are not present in the catalog and to be consulted with the manufacturer through the commercial agent.