

LUFFING JIB TOWER CRANE

















Specifications:

- ▶ Max jib length: 55,00 m
- ▶ Capacity at max length: 3,10 t
- ▶ Max capacity: 18,00 t

WORKS FOR YOU.™

KEY

Legenda · Zeichenerklärung · Légende · Leyenda · Legenda · Условные обозначения

	Hoisting · Sollevamento · Heben · Levage · Elevación · Elevação · Подъем
	Trolleying · Traslazione carrello · Katzfahren · Distribution · Distribución · Distribuição · Передвижение каретки
	Slewing · Rotazione · Schwenken · Orientation · Orientació · Giro · Поворот
	Luffing · Brandeggio · Ausleger-Einziehen · Relevage · Elevación de pluma · Lança basculante · Наклон стрелы
	Travelling · Traslazione · Schienenfahren · Translation · Traslación · Móvel · Передвижение
	Directive on noise level · Direttiva sul livello acustico · Richtlinie für den Schall-Leistungspegel · Directive sur le niveau acoustique · Directiva sobre el nivel acustico · Directiva sobre nivel de ruidos · Директива по уровню шума
	Consult us · Consultateci · Auf Anfrage · Nous consulter · Consultarnos · Consulte-nos · Проконсультироваться с нами
	Power requirements · Potenza totale richiesta · Geforderte Stromstärke · Puissance totale nécessaire · Potencia necesaria · Requisitos de energia · Требования по питанию
	Power supply · Alimentazione · Stromversorgung · Alimentation · Alimentación · Fonte de alimentação · Питание
	In service · In servizio · In Betrieb · En service · En servicio · Em serviço · При работе
	Out of service · Fuori servizio · Außer Betrieb · Hors service · Fuera de servicio · Fora de serviço · В режиме простоя
	Max. under hook height · Altezza max. sotto gancio · Höchste Hakenhöhe · Hauteur maxi. sous crochet · Maxima altura bajo gancho · Alt. máx. sob o gancho · Макс высота крюка
	Jib · Braccio · Ausleger · Flèche · Pluma · Lança · Стрела
	Without load, without ballast, max. jib and max. height · A vuoto, senza zavorra, braccio max., altezza max. · Ohne Last und Ballast, mit Maximalausleger und Maximalhöhe · A vide, sans lest, avec flèche et hauteur maximum · Sin carga, sin lastre, con pluma y altura máxima · Sem carga, sem lastro, lança máxima, altura máxima · Без груза, без балласта, на макс. Длине вспомогательной стрелы и макс. Высоте
	Counterweight · Zavorra controbraccio · Gegengewicht · Lest de contre-flèche · Lastre de contra flecha · Contrapeso · Противовес
C25	EN 14439-C25 · EN 14439 - C25 · EN14439 - C25 · EN 14439 - C25 · EN 14439 - C25 · EN 14439 - C25 · EN14439 - C25

CONTENTS

CTL 260-18

Indice · Inhalt · Contenu · Contenido · Sumário · Содержание

Page · Pagina · Seite · Page · Página · Página · Страница:

Load Diagram · Diagramma di portata · Lastkurven · Courbes de charges · Curvas de cargas · Diagrama de carga · Диаграмма грузоподъёмности	4
Tower · Torre · Turm · Tour · Torre · Torre · Башня	6
Mechanisms · Meccanismi · Antriebe · Mécanismes · Mecanismos · Mecanismo · Механизм	12
Transportation · Trasporto · Transport · Transport · Transporte · Transporte · Транспортировка	14

LOAD DIAGRAM

Diagramma di portata · Lastkurven · Courbes de charges · Curvas de cargas · Diagrama de carga · Схема нагрузок

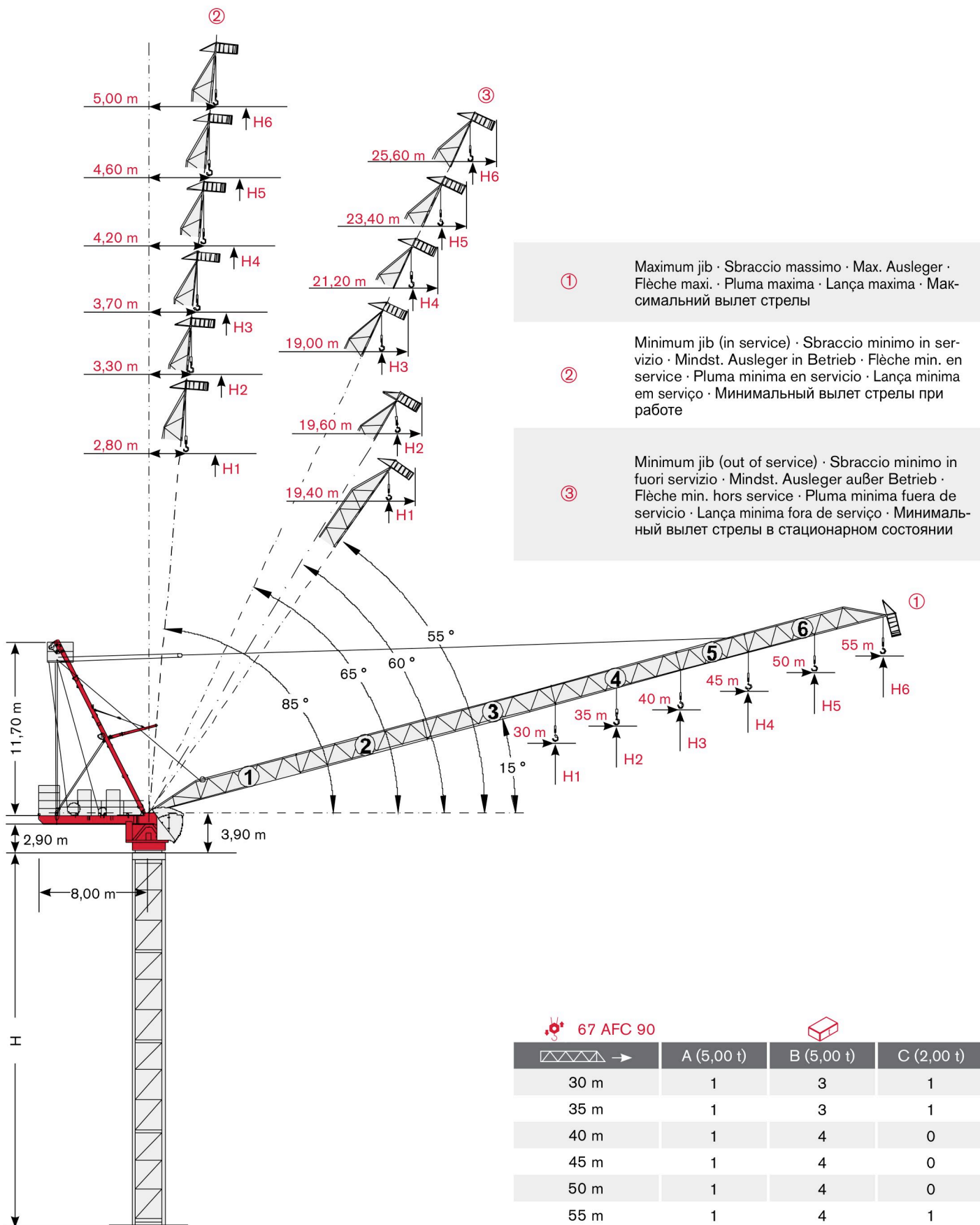

Load Diagram · Diagramma di portata · Lastkurven · Courbes de charges · Curvas de cargas · Diagrama de carga · Диаграмма грузоподъёмности

				15 m	20 m	25 m	30 m	35 m	40 m	45 m	50 m	55 m
	9 t →	27,90 m	t	9,00	9,00	9,00	8,12	6,54	5,36	4,44	3,70	3,10
	13,5 t →	20,40 m	t	13,50	13,50	10,45	8,14	6,50	5,26	4,30	3,53	2,90
	9 t →	31,90 m	t	9,00	9,00	9,00	9,00	7,92	6,54	5,46	4,60	
	13,5 t →	22,60 m	t	13,50	13,50	11,91	9,34	7,50	6,13	5,05	4,20	*
	18 t →	17,90 m	t	18,00	15,76	11,91	9,34	7,50	6,13	5,05	4,20	
	9 t →	32,80 m	t	9,00	9,00	9,00	9,00	8,28	6,88	5,80		
	13,5 t →	23,20 m	t	13,50	13,50	12,30	9,71	7,86	6,48	5,40	*	
	18 t →	18,20 m	t	18,00	16,19	12,30	9,71	7,86	6,48	5,40		
	9 t →	33,70 m	t	9,00	9,00	9,00	9,00	8,60	7,20			
	13,5 t →	23,70 m	t	13,50	13,50	12,64	10,04	8,19	6,80	*		
	18 t →	18,50 m	t	18,00	16,54	12,64	10,04	8,19	6,80			
	9 t →	34,00 m	t	9,00	9,00	9,00	9,00	8,70				
	13,5 t →	23,80 m	t	13,50	13,50	12,70	10,13	8,30	*			
	18 t →	18,60 m	t	18,00	16,55	12,70	10,13	8,30				
	9 t →	30,00 m	t	9,00	9,00	9,00	9,00					
	13,5 t →	23,90 m	t	13,50	13,50	12,77	10,20	*				
	18 t →	18,70 m	t	18,00	16,63	12,77	10,20					

* = + 200 kg [- 50 m - 45 m - 40 m - 35 m - 30 m]

Load diagram not consider rope weight: $p = 1.3 \text{ Kg/m}$ · Diagramma di carico senza peso fune di sollevamento: $p = 1.3 \text{ kg/m}$ · Lastkurven beinhalten nicht das Eigengewicht des Hubseils: $p = 1,3 \text{ Kg/m}$ · La courbe de charge ne tient pas compte du poids du câble $p = 1,3 \text{ kg/m}$ · La tabla de cargas no incluye el peso del cable: $p = 1,3 \text{ kg/m}$ · Diagrama de carga não considera o peso da corda: $p = 1,3 \text{ kg / m}$ · Грузовысотная характеристика составлена без учета веса каната: $p = 1.3 \text{ кг\м}$

Jib and Tower Height Configurations · Configurazioni torre e braccio · Ausleger- und Turmkonfigurationen · Configurations de la flèche et du mât · Configuraciones de pluma y torre · Configuração de lança e altura de torre · Конфигурация башни и стрелы

30 m	1 + 2 + 6
35 m	1 + 2 + 5 + 6
40 m	1 + 2 + 3 + 6
45 m	1 + 2 + 3 + 5 + 6
50 m	1 + 2 + 3 + 4 + 6
55 m	1 + 2 + 3 + 4 + 5 + 6

	H		
	①	②	③
H1	H + 8,50 m	H + 29,20 m	H + 23,70 m
H2	H + 9,80 m	H + 34,40 m	H + 29,60 m
H3	H + 11,10 m	H + 39,60 m	H + 35,80 m
H4	H + 12,50 m	H + 44,80 m	H + 40,50 m
H5	H + 13,80 m	H + 49,90 m	H + 45,20 m
H6	H + 15,10 m	H + 55,00 m	H + 49,90 m

TOWER

Torre · Turm · Tour · Torre · Torre · Башня

Standard Configurations · Installazioni Standard · Standardkonfiguration · Standard Implantations · Implantaciones Standard · Configuração padrão · Стандартная конфигурация крана

H20

Tower: H20 & Basement: RTL

	●	◊
R1	-2300 kN	-3089 kN
R2	1700 kN	2614 kN
	750 kN	

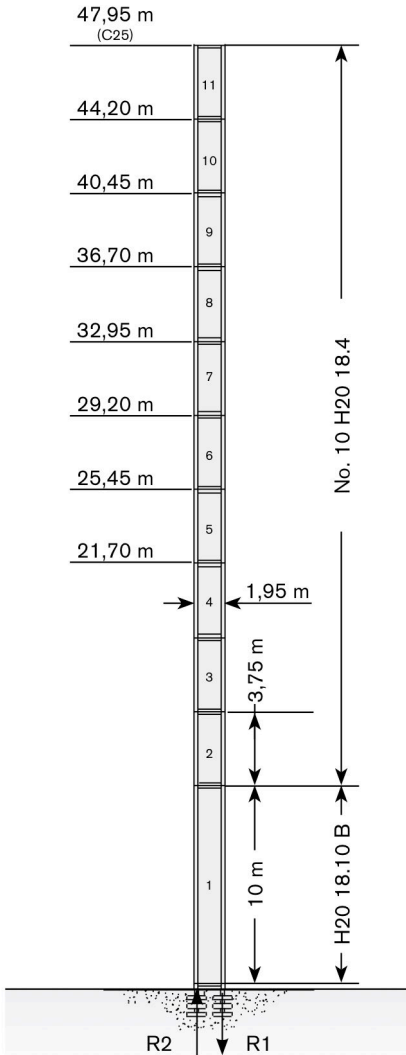

→	max. H (m)	
	FEM 1005 C25	FEM 1001
		
30 m	47,95	47,95
35 m	44,20	47,95
40 m	44,20	47,95
45 m	40,45	44,20
50 m	40,45	40,45
55 m	36,70	40,45

Tower: H20 & Basement: F4

	●	◊
R1	-1282 kN	-1526 kN
R2	-166 kN	0 kN
	830 kN	

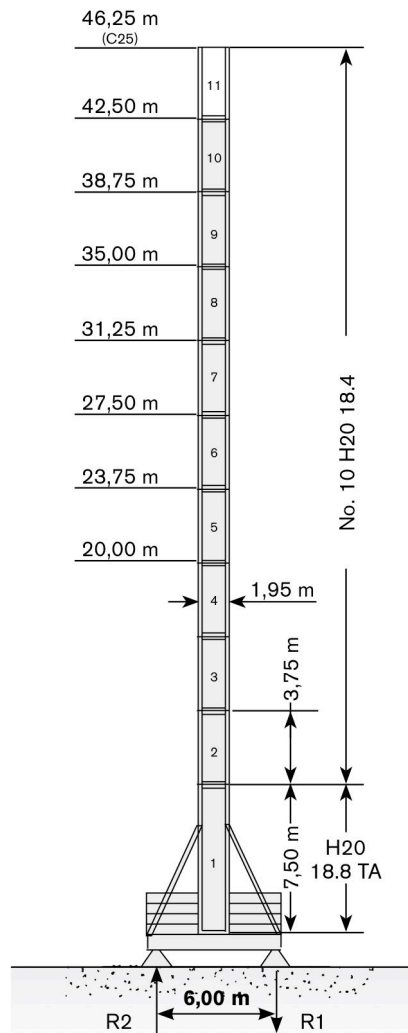

→	max. H (m)	
	FEM 1005 C25	FEM 1001
		
30 m	46,25	46,25
35 m	42,50	42,50
40 m	38,75	38,75
45 m	38,75	38,75
50 m	35,00	38,75
55 m	35,00	35,00

Tower height · Altezza torre · Turmhohe · Hauteur mat · Altura torre · Altura torre · Высота башни

Different heights and tower combinations are available; please consult us · Altezze diverse e combinazioni di torre sono disponibili; consultateci · Andere Höhen und Turmkombinationen auf Anfrage · Différentes hauteurs et combinaisons de tour sont disponibles; nous consulter · Hay diferentes alturas y combinaciones de torre disponibles. Consultenos · Diferentes alturas e combinações de torres disponíveis; fale conosco · Возможны другие сочетания высоты и конфигурации башни; проконсультируйтесь с нами



Other configurations · Altre Installazioni · Aufstellmöglichkeiten · Autres Implantations · Otras Implantaciones · Outras configurações · Другие конфигурации

Bottom climbing crane · Gru climbing · Kletterkran im Gebäude · Télescopage sur dalles · Telescopage grúa trepadora · Guindaste automontante interno · Самоподъемный кран

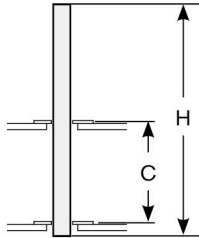

Tower: H20

	C	H
30 m	10,00 m	37,50 m
	11,00 m	41,25 m
	12,00 m	41,25 m
	14,00 m	41,25 m
35 m	10,00 m	33,75 m
	11,00 m	37,50 m
	12,00 m	37,50 m
	14,00 m	37,50 m
40 m	10,00 m	33,75 m
	11,00 m	37,50 m
	12,00 m	37,50 m
	14,00 m	37,50 m
45 m	11,00 m	33,75 m
	12,00 m	33,75 m
	14,00 m	33,75 m
50 m	11,00 m	33,75 m
	12,00 m	33,75 m
	14,00 m	33,75 m
55 m	11,00 m	30,00 m
	12,00 m	30,00 m
	14,00 m	30,00 m

Crane tied to the structure · Gru ancorata · Geankerter Kran · Grue ancrée · Grúa anclada · Guindaste ancorado na estrutura · Кран, крепящийся к сооружению

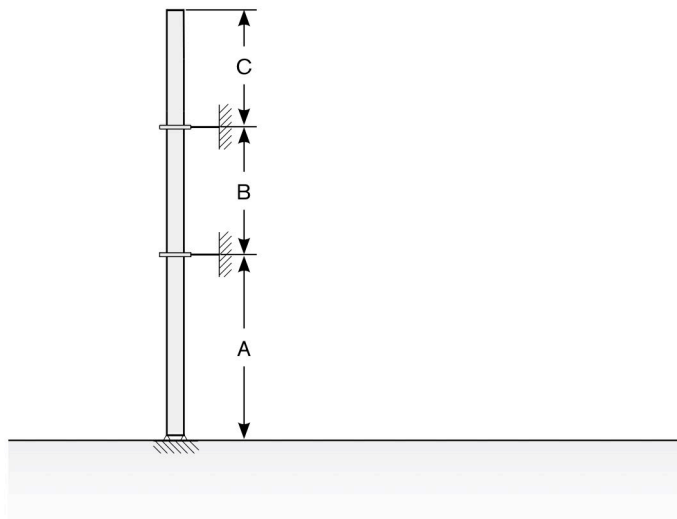

Tower: H20

	A min/max	B min/max	C max
30 m	25 m/35 m	18 m/26 m	29 m
35 m	25 m/35 m	18 m/26 m	29 m
40 m	25 m/35 m	18 m/26 m	29 m
45 m	25 m/32 m	18 m/22 m	27 m
50 m	25 m/32 m	18 m/22 m	27 m
55 m	25 m/28 m	18 m/22 m	25 m

TOWER

Torre · Turm · Tour · Torre · Torre · Башня

Standard Configurations · Installazioni Standard · Standardkonfiguration · Standard Implantations · Implantaciones Standard · Configuração padrão · Стандартная конфигурация крана

HD23

Tower: HD23 & Basement: R1

	●	◊
R1	-2300 kN	-3749 kN
R2	1650 kN	3219 kN
	880 kN	

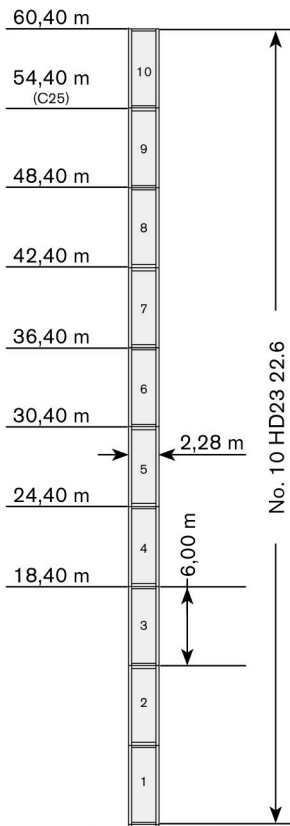

R2 R1

→	max. H (m)	
	FEM 1005 C25	FEM 1001
		
30 m	54,40	60,40
35 m	54,40	60,40
40 m	54,40	54,40
45 m	48,40	54,40
50 m	48,40	54,40
55 m	48,40	48,40

Tower: HD23 & Basement: R2

	●	◊
R1	-2680 kN	-5000 kN
R2	1950 kN	4450 kN
	1020 kN	

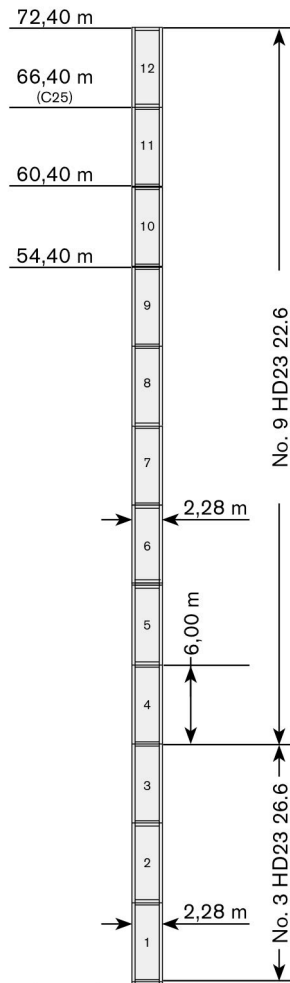

R2 R1

→	max. H (m)	
	FEM 1005 C25	FEM 1001
		
30 m	66,40	72,40
35 m	66,40	72,40
40 m	60,40	66,40
45 m	60,40	66,40
50 m	60,40	60,40
55 m	54,40	60,40

Tower: HD23 & Basement: R3

	●	◊
R1	-3150 kN	-6433 kN
R2	2333 kN	5785 kN
	1130 kN	

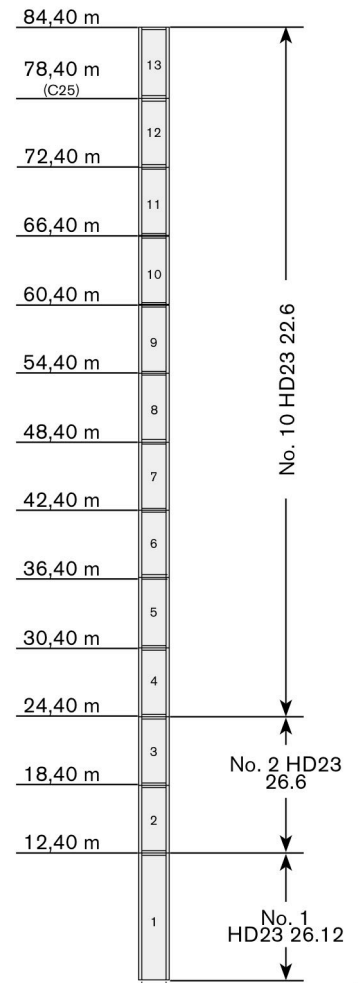

R2 R1

→	max. H (m)	
	FEM 1005 C25	FEM 1001
		
30 m	78,40	84,40
35 m	72,40	84,40
40 m	72,40	78,40
45 m	72,40	78,40
50 m	66,40	78,40
55 m	66,40	72,40

Tower height · Altezza torre · Turmhöhe · Hauteur mat · Altura torre · Altura torre · Высота башни

Different heights and tower combinations are available; please consult us · Altezze diverse e combinazioni di torre sono disponibili; consultateci · Andere Höhen und Turmkombinationen auf Anfrage · Différentes hauteurs et combinaisons de tour sont disponibles; nous consulter · Hay diferentes alturas y combinaciones de torre disponibles. Consultémos · Diferentes alturas e combinações de torres disponíveis; fale conosco · Возможны другие сочетания высоты и конфигурации башни; проконсультируйтесь с нами



Tower: HD23 & Basement: FP1

	●	◊
R1	-1350 kN	-1749 kN
R2	0 kN	0 kN
	1050 kN	

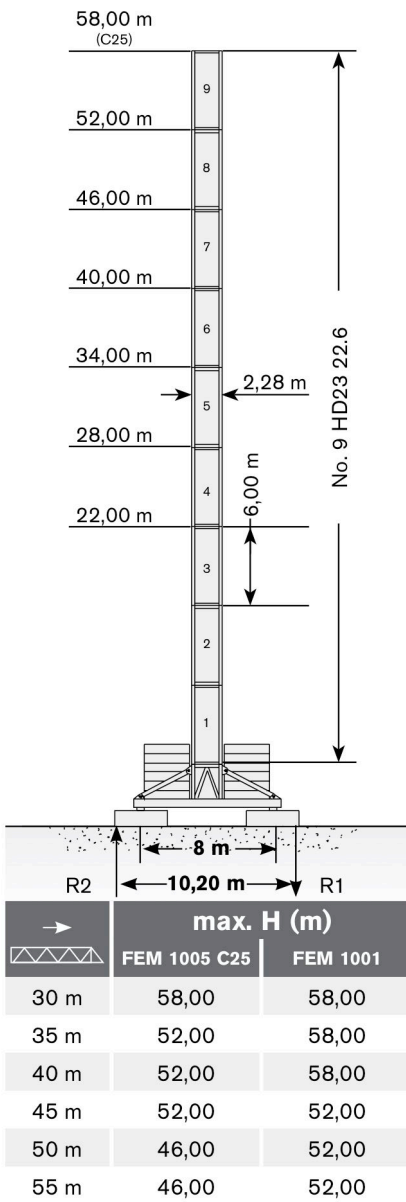

TOWER

Torre · Turm · Tour · Torre · Torre · Башня

Other configurations · Altre Installazioni · Aufstellmöglichkeiten · Autres Implantations · Otras Implantaciones · Outras configurações · Другие конфигурации

Bottom climbing crane · Gru climbing · Kletterkran im Gebäude · Télescope sur dalles · Telescopage grúa trepadora · Guindaste automontante interno · Самоподъемный кран

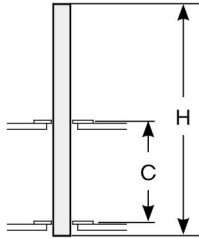

Tower: HD23-22

	C	H
30 m	10,00 m	42,00 m
	12,00 m	48,00 m
	14,00 m	54,00 m
	16,00 m	54,00 m
35 m	10,00 m	36,00 m
	12,00 m	42,00 m
	14,00 m	48,00 m
40 m	14,00 m	48,00 m
	16,00 m	48,00 m
45 m	10,00 m	30,00 m
	12,00 m	36,00 m
	14,00 m	42,00 m
	16,00 m	42,00 m

Crane tied to the structure · Gru ancorata · Geankerter Kran · Grue ancrée · Grúa anclada · Guindaste ancorado na estrutura · Кран, крепящийся к сооружению

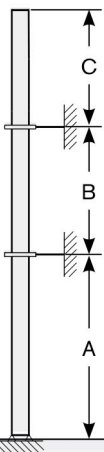

Tower: HD23-22

	A min/max	B min/max	C max
30 m	36 m/48 m	24 m/36 m	30 m
35 m	36 m/42 m	24 m/36 m	24 m
40 m	36 m/42 m	24 m/36 m	24 m
45 m	30 m/36 m	24 m/36 m	21 m
50 m	30 m/36 m	24 m/36 m	21 m
55 m	30 m/36 m	24 m/36 m	21 m

Standard Configurations · Installazioni Standard · Standardkonfiguration · Standard Implantations · Implantaciones Standard · Configuração padrão · Стандартная конфигурация крана

TS23

Tower: TS23 & Basement: R

	●	◊
R1	-1900 kN	-2457 kN
R2	1350 kN	2021 kN
	640 kN	

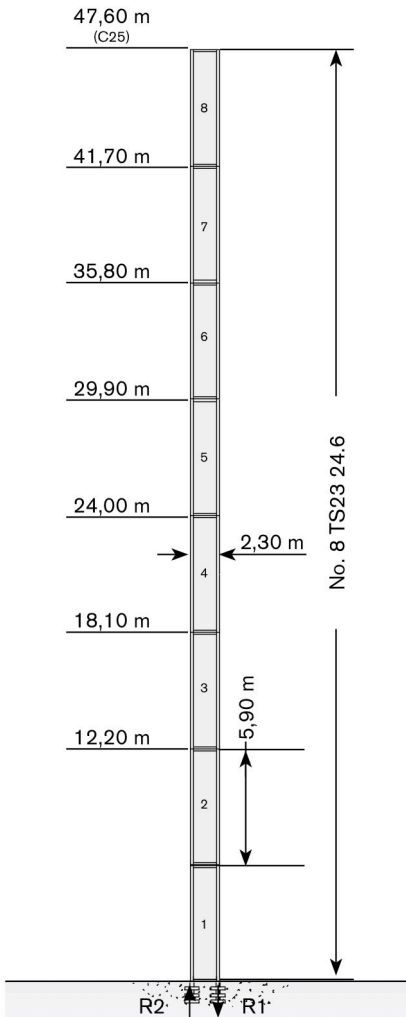

→	max. H (m)	
	FEM 1005 C25	FEM 1001
30 m	47,60	47,60
35 m	47,60	47,60
40 m	41,70	47,60
45 m	41,70	47,60
50 m	41,70	41,70
55 m	35,80	41,70

Tower: TS23 & Basement: F

	●	◊
R1	-1380 kN	-1685 kN
R2	-175 kN	0 kN
	785 kN	

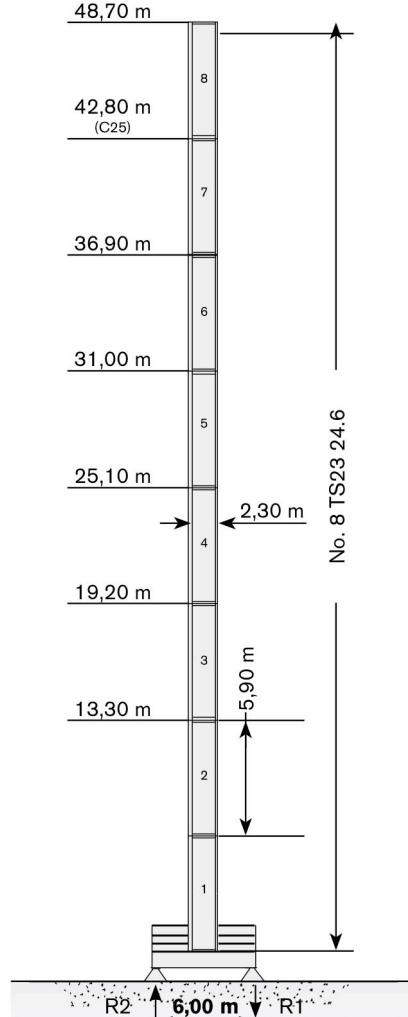

→	max. H (m)	
	FEM 1005 C25	FEM 1001
30 m	42,80	48,70
35 m	42,80	42,80
40 m	36,90	42,80
45 m	36,90	36,90
50 m	36,90	36,90
55 m	31,00	31,00

Tower height · Altezza torre · Turmhohe · Hauteur mat · Altura torre · Altura torre · Высота башни

Different heights and tower combinations are available; please consult us · Altezze diverse e combinazioni di torre sono disponibili; consultateci · Andere Höhen und Turmkombinationen auf Anfrage · Différentes hauteurs et combinaisons de tour sont disponibles; nous consulter · Hay diferentes alturas y combinaciones de torre disponibles. Consúltenos · Diferentes alturas e combinações de torres disponíveis; fale conosco · Возможны другие сочетания высоты и конфигурации башни; проконсультируйтесь с нами

TOWER

Torre · Turm · Tour · Torre · Torre · Башня

Other configurations · Altre Installazioni · Aufstellmöglichkeiten · Autres Implantations · Otras Implantaciones · Outras configurações · Другие конфигурации

Crane tied to the structure · Gru ancorata · Geankerter Kran · Grue ancrée · Grúa anclada · Guindaste ancorado na estrutura · Кран, крепящийся к сооружению

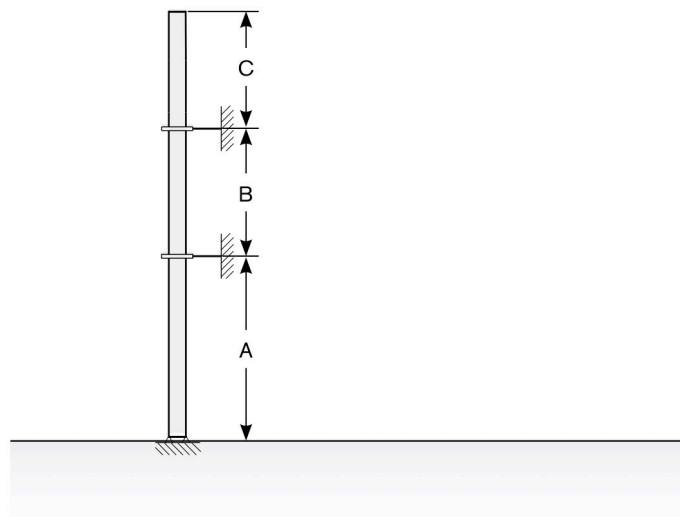

Tower: TS23

 →	A min/max	B min/max	C max
30 m	28 m/34 m	23,6 m/29,5 m	31 m
35 m	22 m/28 m	23,6 m/29,5 m	25 m
40 m	22 m/28 m	23,6 m/29,5 m	25 m
45 m	22 m/28 m	23,6 m/29,5 m	25 m
50 m	16 m/22 m	23,6 m/29,5 m	25 m
55 m	16 m/22 m	23,6 m/29,5 m	25 m

MECHANISMS

CTL 260-18



Meccanismi · Antriebe · Mécanismes · Mecanismos · Mecanismo · Механизм

Power supply · Alimentazione · Stromversorgung · Alimentation · Suministro eléctrico · Requisitos de energia · Требования по питанию

				
	67 AFC 90 - LFC 45	123 kVA*	400V - 50Hz / 460V - 60Hz	2000/14/CE modificata
	67 AFC 90 - LFC 67	165 kVA*	400V - 50Hz / 460V - 60Hz	2000/14/CE modificata

* Average consumption · Consumo medio · Durchschnittsverbrauch · Consommation moyenne · Consumo medio · Consumo médio · Среднее потребление

Hoisting · Sollevamento · Heben · Levage · Elevación · Elevação · Подъем

			t	m/min	kW	
	67 AFC 90 R00 67 AFC 90 R01 (vector)		9	0 → 37	67	560 m (R00) 940 m (R01)
			6	0 → 54		
			4	0 → 77		
			3,7	0 → 82		
			1,5	0 → 130		
		13,5	0 → 25			
		9	0 → 36			
		6	0 → 51			
		5,5	0 → 55			
		2,25	0 → 87			
		18	0 → 19			
		12	0 → 27			
		8	0 → 39			
		7,4	0 → 41			
		3	0 → 65			

MECHANISMS

Meccanismi · Antriebe · Mécanismes · Mecanismos · Mecanismo · Механизм

Hoisting Speed · Velocità di Sollevamento · Heben Geschwindigkeit · Vitesse de Levage · Velocidad de Elevación · Velocidade de içamento · Скорость подъема

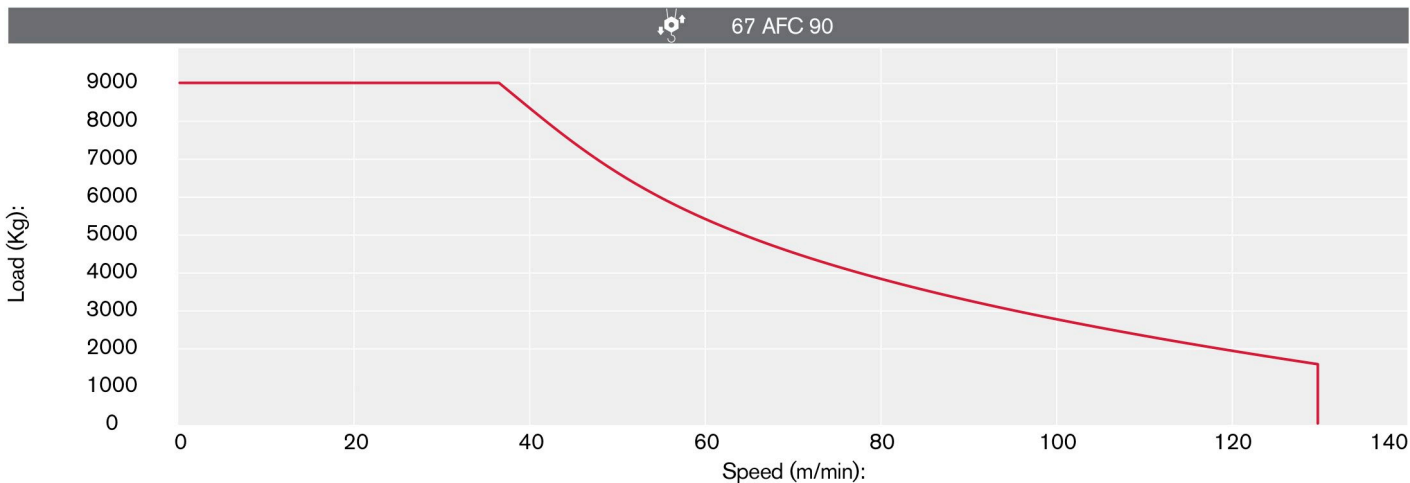













Additional Specifications · Altre movimentazioni · Weitere Leistungsdaten · Spécifications additionnelles · Otras prestaciones · Especificações adicionais · Дополнительные спецификации

↗	LFC 45 R00 / R001 (vector)	2,5 min	45 kW
↗	LFC 67 R00 / R001 (vector)	1,8 min	67 kW
↻	SCC 2 2 112	0 → 0,75 r.p.m.	2 x 10,8 kW



Packing list



Undercarriage

CTL 260-18 H20	DESCRIPTION · DESCRIZIONE · BESCHREIBUNG · DESCRIPTION · DESCRIPCIÓN · DESCRIÇÃO · ОПИСАНИЕ	LENGTH · LUNGHEZZA · LÄNGE · LONGUEUR · LONGITUD · COMPRIMENTO · ДЛИНА	WIDTH · LARGHEZZA · BREITE · LARGEUR · ANCHURA · LARGURA · ШИРИНА	HEIGHT · ALTEZZA · HÖHE · HAUTEUR · ALTURA · ALTURA · · ВЫСОТА	QUANTITY · QUANTITÀ · MENGE · QUANTITÉ · · CANTIDAD · QUANTIDADE · КОЛИЧЕСТВО	WEIGHT · PESO · GEWICHT · POIDS · PESO · PESO · ВЕС
	6x6 m UNDERCARRIAGE LONG BEAM	8,95 m	0,50 m	1,05 m	1	2088 kg
	6x6 m UNDERCARRIAGE SHORT BEAM	4,40 m	0,50 m	1,05 m	2	1010 kg
	6x6 m UNDERCARRIAGE JOINING SLEEPER	5,50 m	0,15 m	0,48 m	2	280 kg
	6x6 m UNDERCARRIAGE JOINING SLEEPER	5,50 m	0,15 m	0,48 m	2	220 kg
	6x6 m UNDERCARRIAGE STRUT	5,10 m	0,24 m	0,30 m	4	500 kg
	STRUT MOUNTING TOWER ELEMENT HA20 18.8TA FOR 6x6 m UNDERCARRIAGE	7,50 m	2,30 m	2,30 m	1	6660 kg*
CTL 260-18 HD23						
	8x8 m UNDERCARRIAGE STRUT MOUNTING TOWER SECTION	2,90 m	2,90 m	2,90 m	1	9150 kg
	8x8 m UNDERCARRIAGE STRUT	4,30 m	0,30 m	2,25 m	4	1820 kg
	8x8 m UNDERCARRIAGE INTERNAL BEAM	4,00 m	0,16 m	0,33 m	4	210 kg
	8x8 m UNDERCARRIAGE EXTERNAL BEAM	5,96 m	0,30 m	0,33 m	4	626 kg
	10x10 m UNDERCARRIAGE STRUT MOUNTING TOWER SECTION	3,00 m	3,00 m	3,10 m	1	10450 kg
	10x10 m LEFT + RIGHT UNDERCARRIAGE STRUT	5,70 m	2,60 m	0,70 m	2 left + 2 right	3825 kg

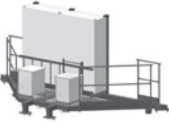

TRANSPORTATION

Trasporto · Transport · Transport · Transporte · Transporte · Транспортировка





CTL 260-18 HD23	DESCRIPTION · DESCRIZIONE · BESCHREIBUNG · DESCRIPTION · DESCRIPCIÓN · DESCRIÇÃO · ОПИСАНИЕ	LENGTH · LUNGHEZZA · LÄNGE · LONGUEUR · LONGITUD · COMPRIMENTO · ДЛИНА	WIDTH · LARGHEZZA · BREITE · LARGEUR · ANCHURA · LARGURA · ШИРИНА	HEIGHT · ALTEZZA · HÖHE · HAUTEUR · ALTURA · ALTURA · · ВЪСОТА	QUANTITY · QUANTITÀ · MENGE · QUANTITÉ · · CANTIDAD · QUANTIDADE · КОЛИЧЕСТВО	WEIGHT · PESO · GEWICHT · POIDS · PESO · PESO · ВЕС
	CROSSBEAM FOR TRAVELLING 10x10 m UNDERCARRIAGE	7,00 m	2,20 m	0,40 m	2	2030 kg
	10x10 m UNDERCARRIAGE ELECTRICAL BOX SUPPORT PLATFORM FOR TVF 4RT 4M9 TRAVELLING DRIVE UNIT	5,70 m	2,20 m	2,40 m	1	1300 kg
	10x10 m UNDERCARRIAGE ELECTRICAL BOX SUPPORT PLATFORM FOR TSR 4RG 4M8 TRAVELLING DRIVE UNIT	5,60 m	2,10 m	3,70 m	1	645 kg



CTL 260-18 TS23						
	"A" BEAM FOR 6x6 m TS23 UNDERCARRIAGE	8,89 m	0,85 m	1,24 m	1	4620 kg
	"B" BEAM FOR 6x6 m TS23 UNDERCARRIAGE	8,89 m	0,55 m	1,44 m	1	5010 kg
	CROSSBEAM FOR UNDERCARRIAGE TS23 (Travelling version)	5,41 m	0,45 m	0,18 m	2	440 kg

Tower



CTL 260-18 H20						
	HA20 18.10 B TOWER ELEMENT	10,00 m	2,00 m	1,95 m	1	7000 kg*
	HA20 18.4 S TOWER ELEMENT	3,75 m	2,00 m	1,95 m	1	2955 kg*
	H20 SLEWING RING SUPPORT	2,65 m	2,30 m	3,70 m	1	10140 kg

* including ladders, platforms, assembly equipment and strut mounting brackets

CTL 260-18 HD23	DESCRIPTION · DESCRIZIONE · BESCHREIBUNG · DESCRIPTION · DESCRIPCIÓN · DESCRIÇÃO · ОПИСАНИЕ	LENGTH · LUNGHEZZA · LÄNGE · LONGUEUR · LONGITUD · COMPRIMENTO · ДЛИНА	WIDTH · LARGHEZZA · BREITE · LARGEUR · ANCHURA · LARGURA · ШИРИНА	HEIGHT · ALTEZZA · HÖHE · HAUTEUR · ALTURA · ALTURA · ВЫСОТА	QUANTITY · QUANTITÀ · MENGE · QUANTITÉ · CANTIDAD · QUANTIDADE · КОЛИЧЕСТВО	WEIGHT · PESO · GEWICHT · POIDS · PESO · PESO · ВЕС
	TOWER SECTION HD23 26.6	6,00 m	2,34 m	2,32 m	1	6300 kg**
	TOWER SECTION HD23 26.3	3,00 m	2,34 m	2,32 m	1	3658 kg**
	TOWER SECTION HD23 22.6	6,00 m	2,28 m	2,29 m	1	4675 kg**
	TOWER SECTION HD23 22.3	3,00 m	2,29 m	2,28 m	1	2660 kg**
	HD23 SLEWING RING SUPPORT	2,97 m	2,30 m	2,75 m	1	10520 kg

CTL 260-18 TS23						
	TS23 24.3 TOWER SECTION	2,95 m	2,33 m	2,25 m	1	2150 kg
	TS23 24.6 TOWER SECTION	5,90 m	2,33 m	2,25 m	1	3700 kg
	TS23 SLEWING RING SUPPORT	2,98 m	2,30 m	2,75 m	1	9500 kg

Cab

CTL 260-18						
	CAB SUPPORT PLATFORM + EVO1 + ELECTRICAL BOX	4,00 m	1,51 m	2,50 m	1	1140 kg
	CAB SUPPORT PLATFORM + EVO15 + ELECTRICAL BOX	4,54 m	1,98 m	2,44 m	1	1850 kg

TRANSPORTATION

Trasporto · Transport · Transport · Transporte · Transporte · Транспортировка

Upper Part

CTL 260-18	DESCRIPTION · DESCRIZIONE · BESCHREIBUNG · DESCRIPTION · DESCRIPCIÓN · DESCRIÇÃO · ОПИСАНИЕ	LENGTH · LUNGHEZZA · LÄNGE · LONGUEUR · LONGITUD · COMPRIMENTO · ДЛИНА	WIDTH · LARGHEZZA · BREITE · LARGEUR · ANCHURA · LARGURA · ШИРИНА	HEIGHT · ALTEZZA · HÖHE · HAUTEUR · ALTURA · ALTURA · ВЫСОТА	QUANTITY · QUANTITÀ · MENGE · QUANTITÉ · CANTIDAD · QUANTIDADE · КОЛИЧЕСТВО	WEIGHT · PESO · GEWICHT · POIDS · PESO · PESO · ВЕС
	COUNTERJIB (complete of handrails, hold-to-position frame without winches)	8,40 m	3,60 m	1,95 m	1	7200 kg
	LUFFING WINCH 45 kW R00 / R01 (complete of ropes)	2,73 m	1,85 m	1,75 m	1	3230 kg
	LUFFING WINCH 67 kW R00 / R01 (complete of ropes)	2,82 m	1,93 m	1,95 m	1	3850 kg
	HOIST WINCH 67 kW R00 (complete of ropes)	2,37 m	2,23 m	1,95 m	1	3855 kg
	HOIST WINCH 67 kW R01 (complete of ropes)	2,37 m	2,23 m	1,95 m	1	4412 kg
	COUNTERJIB A-FRAME UNIT	7,88 m	2,45 m	12,11 m	1	4650 kg
	JIB SECTION-1	10,56 m	1,76 m	1,87 m	1	1782 kg
	JIB SECTION-2	10,53 m	1,76 m	1,70 m	1	1235 kg
	JIB SECTION-3	10,53 m	1,76 m	1,70 m	1	1084 kg
	JIB SECTION-4	10,53 m	1,76 m	1,70 m	1	983 kg
	JIB SECTION-5	5,63 m	1,76 m	1,70 m	1	532 kg
	JIB SECTION-6	10,61 m	1,76 m	1,84 m	1	1310 kg
	2-FALLS LINE HOIST BLOCK	1,20 m	0,53 m	1,03 m	1	360 kg
	4-FALLS LINE HOIST BLOCK	0,52 m	0,26 m	0,98 m	1	300 kg