

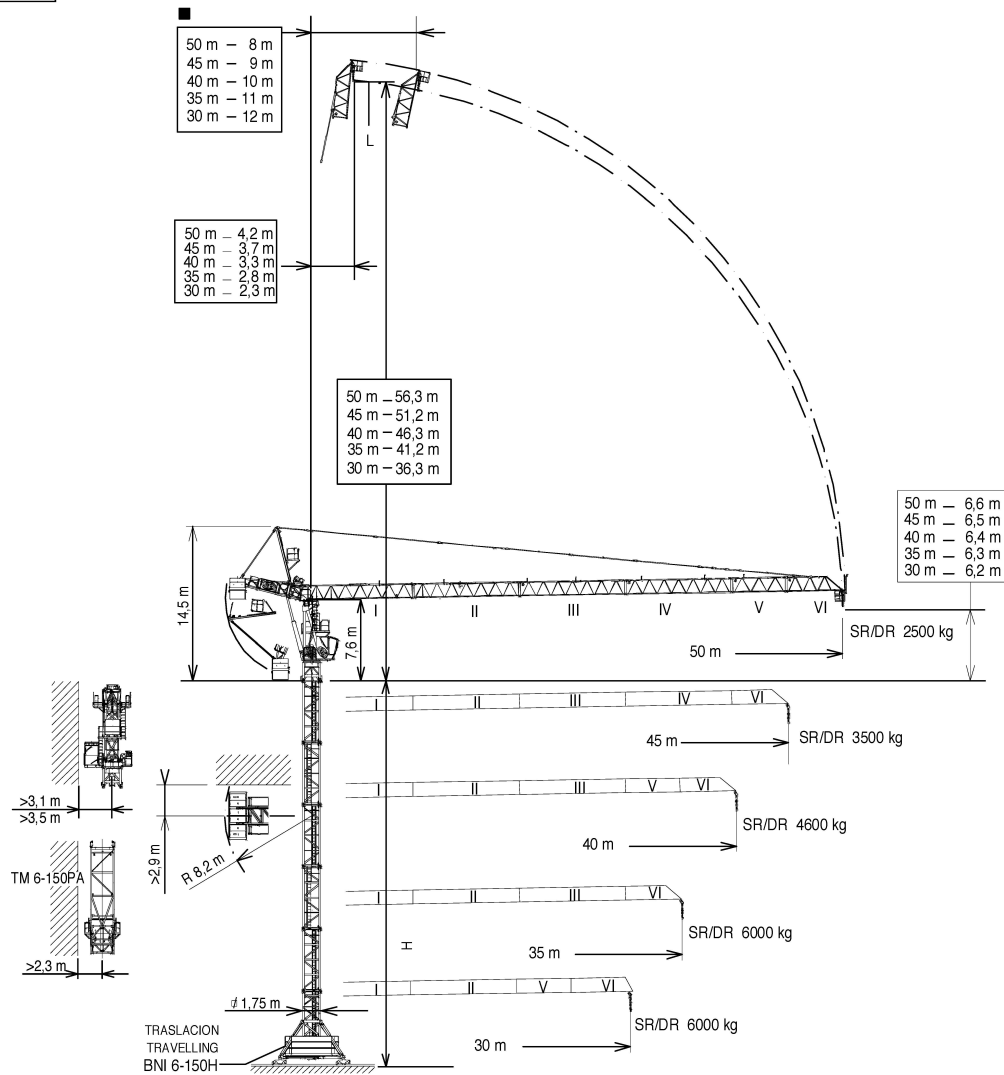

UNE 58-101  
FEM 1001

UNE-EN-ISO 9001



Máxima altura de torre sin arriostrar (m).

Maximum tower height without fastening (m).

Hauteur maximale de tour sans ancrage (m).

Максимальная высота башни без крепления (м).

Desteksiz maksimum kule yüksekliği (m).

أقصى ارتفاع للبرج بدون ربط (م)

H =

\* Tramo pluma / Jib section / Tronçon de flèche / Секция стрелы / Bom bölümü / أجزاء الذراع

\*\* Punta de pluma / Jib end / Pointe de flèche / Конец стрелы / Bom ucu / مقدمة الذراع

\*Tramo pluma I / Jib section I ----- 208.40.000

\*Tramo pluma II / Jib section II ----- 208.41.000

\*Tramo pluma III / Jib section III --- 208.42.000

\*Tramo pluma IV / Jib section IV --- 208.43.000

\*Tramo pluma V / Jib section V --- 208.44.200

\*Tramo pluma VI / Jib section VI --- 208.45.700

\*\*Punta pluma/Jib end ----- 208.45.000

TM 6-150PA -----161.35.500

T3-150-----161.32.000

T6-150-----161.31.000

TD6-150 -----161.31.700

T12-150 ----- 161.31.500

AN 150 -----161.21.000

BNI 6-150 -----161.20.000

ABH 100 -----201.23.000

(H) TRASLACION / TRAVELLING /

TRASLACION / ПЕРЕМЕЩЕНИЕ / RAY YÜRÜYÜŞLÜ / متحركة

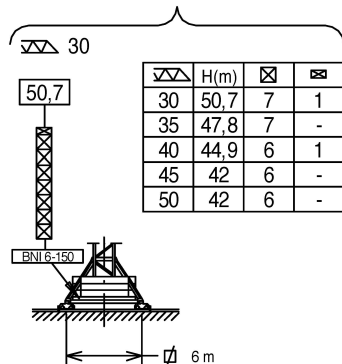

(H) ESTACIONARIA / STATIONARY /

STATIONAIRE / СТАЦИОНАРНОЕ СОСТОЯНИЕ / SABIT / ثابتة

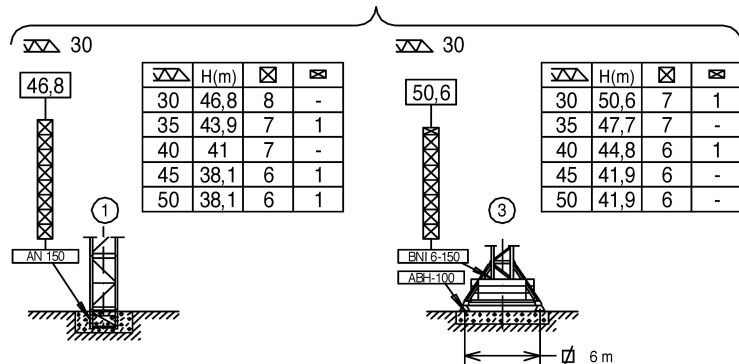

☒ T3-150

☒ T6-150

☒ TD6-150



☒ T12-150







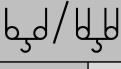



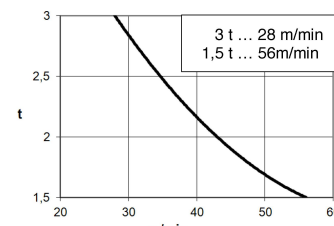
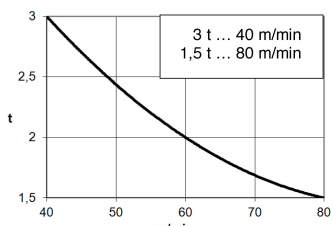
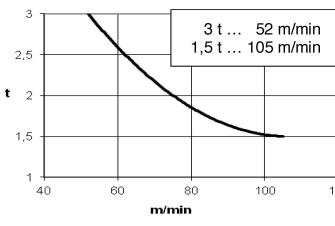

Fecha / Date: 10/06/2019

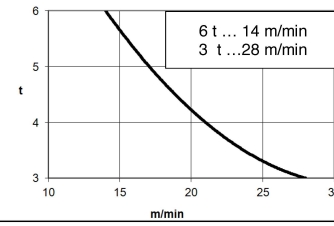
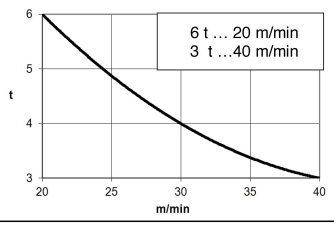
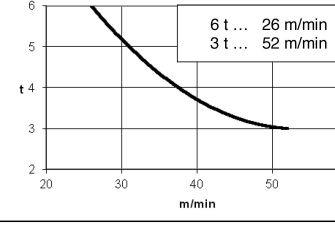

Reservado el derecho a modificaciones sin previo aviso. Declinamos toda responsabilidad derivada de la información proporcionada / Subject to modification, without previous warning. This information is supplied without liability / L'entreprise se réserve le droit de procéder à des modifications sans préavis. Nous déclinons toute responsabilité quant aux informations fournies / Мы оставляем за собой право на внесение изменений без предварительного уведомления. Мы снимаем с себя любую ответственность в отношении предоставленной информации / Önceden bildirilmeksizin değiştirilme hakkı saklıdır. Verilen bilgiler için hiçbir sorumluluk kabul etmemekteyiz. حقوق التغيير محفوظة دون إشعار مسبق. دون أدنى مسؤولية عن المعلومات المقدمة

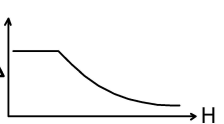

 SR/DR (kg)		Cargas máximas / Maximum loads / Charges maximales / Максимальные нагрузки / Maksimum yük / أقصى حمولة <b>SR/DR - 3000/6000 kg</b>					
 [m]	3000/6000 kg @ ... (m)	Alcance del gancho [m] / Hook reach [m] / Portée du crochet (m) / Радиус действия крюка (m) / Kancanın yüksekliği (m) / مدى الخطاف (m)					
		25	30	35	40	45	50
50 m	47,4/28,6	3000/6000	3000/5685	3000/4725	3000/3965	3000/3310	2500
45 m	45,0/31,5	3000/6000	3000/6000	3000/5310	3000/4470	3000/3500	—
40 m	40,0/34,1	3000/6000	3000/6000	3000/5815	3000/4600	—	—
35 m	35,0	3000/6000	3000/6000	3000/6000	—	—	—
30 m	30,0	3000/6000	3000/6000	—	—	—	—

*opcional *optional *en option *опция *opsiyonel *اختياري							
		<b>EC2556VF</b> <b>18,4 kW</b>	<b>*EC3380VF</b> <b>24,2 kW</b>	<b>EC40105VF</b> <b>29,4 kW</b>			
 t m/min							
	 t m/min						
						 H $H \leq \begin{matrix} SR & 452 \text{ m} \\ DR & 226 \text{ m} \end{matrix}$	
				 400V 50Hz			
<b>TG2020VF</b> <b>2x7,3 kW</b>	<b>OG1108VF</b> <b>2x4 kW</b>	<b>EPH2020VF</b> <b>15 kW</b>	<b>TH1506</b> <b>11 kW</b>	<b>P<sub>TOTAL</sub> (EC2556VF + OG1108VF + EPH2020VF) = 41,4 kW</b> <b>P<sub>TOTAL</sub> (*EC3380VF + OG1108VF + EPH2020VF) = *47,2 kW</b>			
0...20 m/min	0... 0,8 r/min sl/min	2 min	0,6 m/min	  			

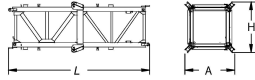
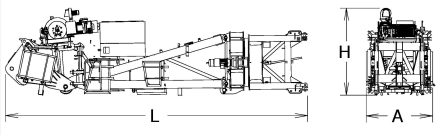
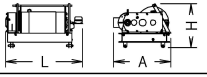
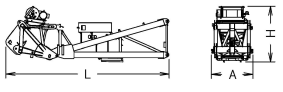
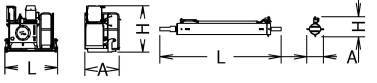
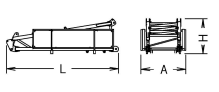
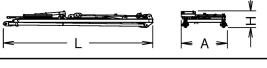
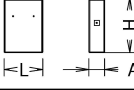
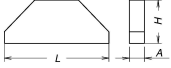
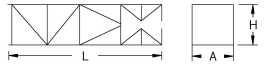
DENOMINACIÓN / DENOMINATION / DÉSIGNATION / НАЗВАНИЕ / AÇIKLAMA / اسم		L [m]	A [m]	H [m]	P / W [kg]	
Torre inferior / Lower tower / Tour inférieure / Нижняя башня Alt kule / البرج السفلي	TI-6-150		6,175	2,190	2,190	3.535
Torre / Tower / Tour Башня / Kule / برج	T6-150		6,175	1,870	1,870	2.760
	TD6-150		6,175	1,870	1,870	2.930
	TT6-150		6,175	1,870	1,870	2.760
	T3-150		3,265	1,870	1,870	1.550
	T12-150		12,000	1,870	1,870	5.180
Torre asiento pista + base punta de torre + orientación Slewing table + tower head base + slewing mechanism Tour pivot + base du porte-flèche + mécanisme d'orientation Сиденье площадки + основание верхней секции башни + поворотный механизм Göbek +kule kafa bölümü tabanı+mekanizma / رج وحدة الدوران + قاعدة رأس البرج + آلية الدوران			3,265	2,100	2,040	5500
Conjunto asiento pista, punta de torre, orientación y elevación Slewing table assembly, tower head, slewing and hoisting mechanism Groupe pivot + porte-flèche + mécanisme d'orientation + de levage Сиденье площадки + верхняя секция башни + поворотный механизм + подъемный механизм Göbek +kulenin kafa bölümü+mekanizma+vinç kulesi مجموعة وحدة الدوران + رأس البرج + آلية الدوران + آلية الرفع			9,710	2,100	2,510	12100
Tramo de pluma Jib section Tronçon de flèche Секция стрелы Вот bölümü أجزاء الذراع	[I] [II] [III] [IV] [V] [VI]		10,265 10,165 10,160 10,160 5,270 5,636	1,355 1,215 1,215 1,205 1,205 1,230	1,485 1,485 1,465 1,465 1,465 1,580	1265 970 836 745 370 435
Punta de pluma / Jib end / Pointe de flèche / Конец стрелы / Вот усу / مقدمة الذراع			1,185	0,550	0,685	112
Mecanismo elevación carga / Hoisting mechanism / mécanisme de levage/ подъемный механизм / Vinç kulesi / آلية الرفع			1,430	1,060	0,800	810
Punta de torre + Elevación carga / Tower head + hoisting mechanism Porte-flèche + mécanisme de levage / Верхняя секция башни + подъемный механизм Kulenin kafa bölümü + Vinç kulesi / رأس البرج + آلية الرفع			7,200	1,850	2,485	6600
Elevación pluma con plataforma / Luffing mech + platform / Releavage de flèche + plateform + Подъем стрелы + Платформа + Yük kaldırma ve indirme + Platform / رافع الذراع + كابينه Clindro hidráulico / Hydraulic cylinder / Cylindre hydraulique /			1,685 3,865	1,100 0,520	1,465 0,650	740 1750
Polipasto / Hook assembly / Palan / Полуснаст / Kanca takımı / ككرة Gancho / Hook			0,835	0,235	1,175	220
Tirante sostén pluma / Jib support tie / Tirant de fleche / Растяжка поддержки стрелы / Kol destek bağları / مشد دعامة الذراع			6,305	0,360	0,370	1200
Contrapluma con plataformas + Soporte contrapeso / Counterjib with platforms + Counterweight support Contre-flèche avec plateformes / Противовесная консоль с платформами / Platformlu kuyruk / الذراع المقابل مع المنصة			5,260	2,100	1,580	2460
Parte superior Top part			5,740	1,760	0,680	770
Plataforma y cabina / Platform and cabin / Plateforme et cabine Платформа и кабина / Platform ve kabin / منصة وكابينة			4,150	2,100	2,500	1200
Contrapeso / Counterweight / Contrepoids / Противовес / Denge ağırlığı / اوزان معاكسة			1,486	0,600	2,125	4100
			1,486	0,600	1,750	3500
			1,486	0,600	0,905	1650
Lastre / Ballast / Lest / Балласт / Alt ağırlık taşları / ثقل			3,800	0,580	1,500	6000
Estructura torre de montaje / Jacking cage structure / Structure de tour de montage / Структура монтажной башни / Kaldırma kafesi yapısı هيكل برج التركيب	TM6-150		10,320	2,420	2,310	3.500



Fecha / Date: 10/06/2019

Reservado el derecho a modificaciones sin previo aviso. Declinamos toda responsabilidad derivada de la información proporcionada / Subject to modification, without previous warning. This information is supplied without liability / L'entreprise se réserve le droit de procéder à des modifications sans préavis. Nous déclinons toute responsabilité quant aux informations fournies / Мы оставляем за собой право на внесение изменений без предварительного уведомления. Мы снимаем с себя любую ответственность в отношении предоставленной информации / Önceden bildirilmeksizin değiştirilme hakkı saklıdır. Verilen bilgiler için hiçbir sorumluluk kabul etmemekteyiz  
حقوق التغيير محفوظة دون إشعار مسبق. دون أدنى مسؤولية عن المعلومات المقدمة

T	H	Component	Height (m)	Section	Height (m)	Section
1	6,2	T 6-150	2,91	3,3	1	
2	12	T 6-150	5,82	9,1	2	
3	17,8			14,9	3	
4	23,7			20,7	4	
5	29,5			26,5	5	
6	35,3			30,5	6	
7	39,2	TL20/TX150	32,4	36,3	7	
8	44,8	TL20-5,6	38,3	41,9	8	
9	50,4	TS20-5,6A	42,1	47,5	9	
10	56	TSR20-5,6A	47,7	53,1	10	
11	61,6		53,3	58,7	11	
12	67,2	TSR20-5,6	58,9	64,3	12	
			64,5	70,1	13	

ASR 20: 160.21.200 ASR 20  
 T3-150: 161.32.000 ASR 20  
 T6-150: 161.31.000 ASR 20  
 TL20/TX50: 161.36.000 ASR 20  
 TL20-5,6: 204.31.400 ASR 20  
 TS20-5,6A: 204.31.500 TSR20-5,6A: 204.31.300 ASR 20  
 TS20-5,6: 204.31.200 TSR20-5,6: 204.31.000 ASR 20

T: Torre / Tower / Tour / Башни / Kuleler / أبراج  
 H: Altura / Height / Hauteur / Высота / Yükseklik / ارتفاع

Otras configuraciones de torre / Other tower configuration / Autres configurations / Прочие конфигурации / Diğer konfigürasyonlar / مكونات أخرى

Transporte / Transport / Transport / Транспортировка / Taşıma / نقل

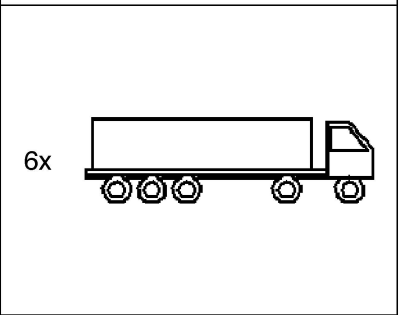
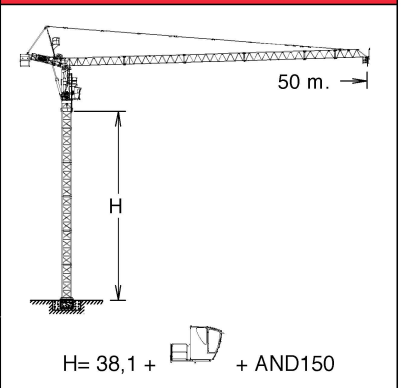

6x HIGH CUBE 40'

h (m)	35
D (m)	13 - 16
P (KN)	800 740
Rmax (KN)	151 330

h<sub>max</sub>: T6150T + 4xT6-150

T6-150T: 161.32.500

Trepado interno / Internal climbing. / Télescopage intérieur / Внутренняя лестница / Vına içi tırmanma / التسلق الداخلي

- ⚠ Viento fuera de servicio / Out of service wind / Vitesse du vent hors service / Ветровая нагрузка в покое / Rüzgar devre dışı / الرياح خارج الخدمة
- ℹ Consultar / Consult / Nous consulter / Консультируйтесь / Danışınız / الرجوع إلى
- ▶ En servicio / In service / En service / В работе / Devrede / في الخدمة
- Fuera de servicio / Out of service / Hors service / В покое / Devre dışı / خارج الخدمة



Ctra./Rd. Madrid - Irún Km. 415 - 20.213 IDIAZABAL [Gipuzkoa] ESPAÑA / SPAIN  
 P.O. Box, 23 - 20.200 BEASAIN - E-mail: jaso@jaso.com  
 Tel. +34 943 - 18 70 00 • Fax. +34 943 - 18 70 20  
 www.jaso.com

Fecha / Date: 10/06/2019

FEM 1001

DELEGACION / DEALER

Reservado el derecho a modificaciones sin previo aviso. Declinamos toda responsabilidad derivada de la información proporcionada / Subject to modification, without previous warning. This information is supplied without liability / L'entreprise se réserve le droit de procéder à des modifications sans préavis. Nous déclinons toute responsabilité quant aux informations fournies / Мы оставляем за собой право на внесение изменений без предварительного уведомления. Мы снимаем с себя любую ответственность в отношении предоставленной информации / Önceden bildirilmeksizin değiştirilme hakkı saklıdır. Verilen bilgiler için hiçbir sorumluluk kabul etmemekteyiz /

حقوق التغيير محفوظة دون إشعار مسبق دون أدنى مسؤولية عن المعلومات المقدمة