

H_{SR} =

Altura máxima bajo gancho sin arriostrar (m).
Maximum height under hook without fastening (m).
Hauteur maximale sous crochet sans ancrage (m).
Максимальная высота под крюком без крепления (m).
Bağlantısız maksimum kanca altı yüksekliği (m).
أقصى ارتفاع تحت الخطاف بدون ربط (m)

TM 6-150	161.35.700	ABH 100	201.23.000
T3-90	133.32.000	P14-1R	145.40.500
T6-90	133.31.000	P14-2N	145.41.500
T6-150	161.31.000	P14-16R	145.42.800
T6-150A	161.31.300	P14-4N	145.43.000
AN 90	133.21.000	P14-17N	145.44.500
AN 150	161.21.000	P14-15N	145.45.500
BNI 45-100	145.20.500	P14-6N	145.45.000
BNI 6-150	161.20.700	P14-8N	145.47.500

(H) TRASLACIÓN / TRAVELLING /
TRASLACION / ПЕРЕМЕЩЕНИЕ / RAY YÜRÜYÜŞLÜ / متحركة

(H) ESTACIONARIA / STATIONARY /
STATIONAIRE / СТАЦИОНАРНОЕ СОСТОЯНИЕ / SABIT / ثابتة

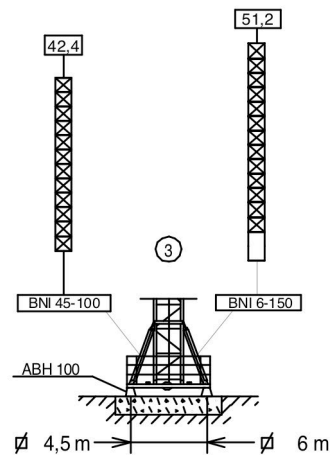
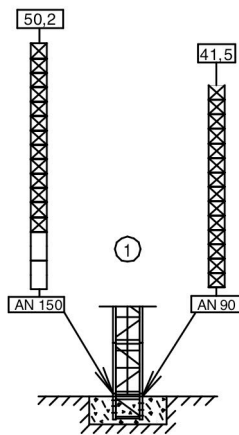
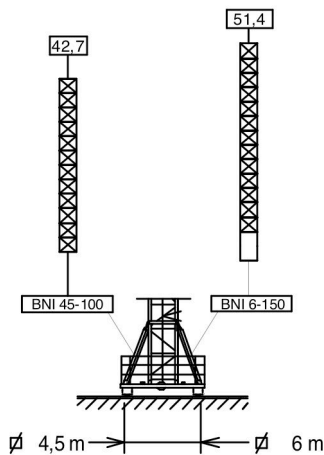

- T3-90
- T6-90
TD 6-90
- T6-150A
- T6-150
TD 6-150

Fecha / Date: 20/10/2016









Reservado el derecho a modificaciones sin previo aviso. Declinamos toda responsabilidad derivada de la información proporcionada / Subject to modification, without previous warning. This information is supplied without liability / L'entreprise se réserve le droit de procéder à des modifications sans préavis. Nous déclinons toute responsabilité quant aux informations fournies / Мы оставляем за собой право на внесение изменений без предварительного уведомления. Мы снимаем с себя любую ответственность в отношении предоставленной информации / Onceden bildirilmeksizin değiştirilme hakkı saklıdır. Verilen bilgiler için hiçbir sorumluluk kabul etmemekteyiz / حقوق التغيير محفوظة دون إشعار مسبق. دون أدنى مسؤولية عن المعلومات المقدمة

ST-SR (kg)		Cargas máximas / Maximum loads / Charges maximales / Максимальные нагрузки / Maksimum yük / أقصى حمولة SR-4.000 kg							
[m]	4000 kg @ ... (m)	Alcance del gancho [m] / Hook reach [m] / Portée du crochet (m) / Радиус действия крюка (m) / Kancanın yüksekliği (m) / مدى الخطاف							
		25	30	35	40	45	50	55	60
60 m	25,5 m	4000	3290	2720	2295	1960	1695	1480	1300
55 m	29,2 m	4000	3875	3220	2730	2350	2045	1800	—
50 m	29,2 m	4000	3900	3400	3025	2735	2500	—	—
45 m	32,5 m	4000	4000	3665	3120	2700	—	—	—
40 m	33,2 m	4000	4000	3755	3200	—	—	—	—
35 m	33,5 m	4000	4000	3800	—	—	—	—	—
30 m	30,0 m	4000	4000	—	—	—	—	—	—
25 m	25,0 m	4000	—	—	—	—	—	—	—

ST-DR (kg)		Cargas máximas / Maximum loads / Charges maximales / Максимальные нагрузки / Maksimum yük / أقصى حمولة DR - 8.000 kg									
[m]	8000 kg @ ... (m)	Alcance del gancho [m] / Hook reach [m] / Portée du crochet (m) / Радиус действия крюка (m) / Kancanın yüksekliği (m) / مدى الخطاف									
		15	20	25	30	35	40	45	50	55	60
60 m	13,7 m	7225	5180	3955	3140	2555	2120	1780	1505	1285	1100
55 m	15,6 m	8000	6045	4650	3715	3050	2550	2165	1850	1600	—
50 m	15,6 m	8000	6175	4885	4025	3410	2945	2585	2300	—	—
45 m	17,3 m	8000	6800	5250	4220	3480	2930	2500	—	—	—
40 m	17,6 m	8000	6940	5365	4310	3560	3000	—	—	—	—
35 m	17,8 m	8000	7005	5415	4355	3600	—	—	—	—	—
30 m	17,3 m	8000	6770	5225	4200	—	—	—	—	—	—
25 m	17,2 m	8000	6735	5200	—	—	—	—	—	—	—

CARACTERISTICAS DE MECANISMOS / MECHANISMS FEATURES / CARACTÉRISTIQUES DES

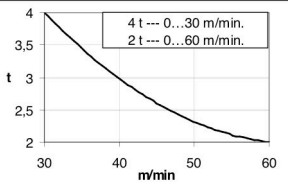
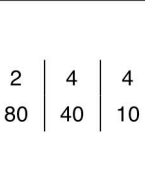
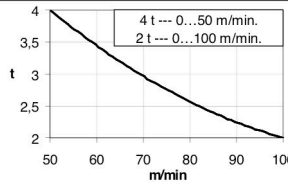
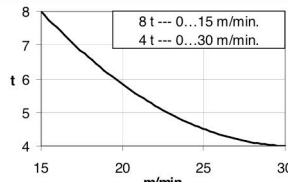
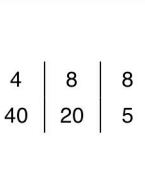
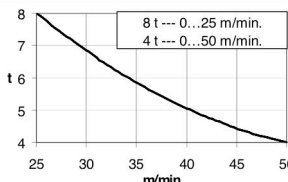
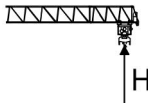
MÉCANISMES / ХАРАКТЕРИСТИКИ МЕХАНИЗМОВ / MEKANİZMALARIN ÖZELLİKLERİ / الخصائص الآلية

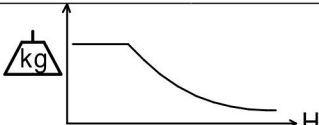
*opcional / *optional / *en option / *опция / *opsiyonel / اختياري													
		EC3360VF 24,3 kW	*EC4880 35,3 kW	*EC60100VF 44,1 kW	TG1125VF 2x4 kW	OG1508VF 2x5,5 kW	TC465VF 3 kW	TH1210 9,2 kW					
						0...25 m/min		0...0,8 r/min sl/min		0...15 15...32 32...65 m/min		1 m/min	
						400V 50Hz		P_{TOTAL}(EC3360VF+ OG1508VF + TC465VF) = 38,3 kW P_{TOTAL}(EC4880+ OG1508VF + TC465VF) = 49,3 kW P_{TOTAL}(EC60100VF+ OG1508VF + TC465VF) = 58,1 kW		480V 60Hz		EC4880 TH1210 kW +20% m/min +20%	
		$H \leq$ SR 322 m DR 161 m		$H \leq$ SR 534 m DR 267 m									



Fecha / Date: 20/10/2016









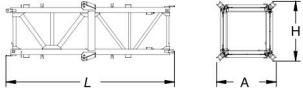
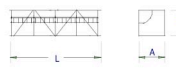
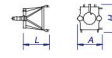

FEM 1005 - C25

Reservado el derecho a modificaciones sin previo aviso. Declinamos toda responsabilidad derivada de la información proporcionada / Subject to modification, without previous warning. This information is supplied without liability / L'entreprise se réserve le droit de procéder à des modifications sans préavis. Nous déclinons toute responsabilité quant aux informations fournies / Мы оставляем за собой право на внесение изменений без предварительного уведомления. Мы снимаем с себя любую ответственность в отношении предоставленной информации / Onceden bildirilmeksizin değiştirilme hakkı saklıdır. Verilen bilgiler için hiçbir sorumluluk kabul etmemekteyiz / حقوق التغيير محفوظة دون إشعار مسبق. دون أدنى مسؤولية عن المعلومات المقدمة

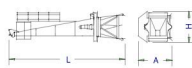
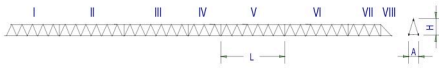
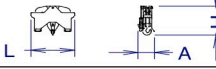
LISTA DE EMBARQUE / PACKING LIST /

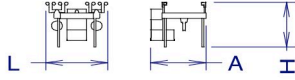
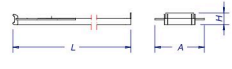
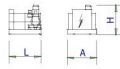
J118.8

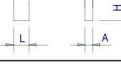
LISTE DE COLISAGE / СПИСОК ПОСТАВКИ / ÇEKİ LİSTESİ / قائمة التحميل

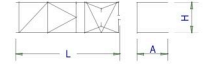
DENOMINACIÓN / DENOMINATION / DÉSIGNATION / НАЗВАНИЕ / AÇIKLAMA / اسم		L [m]	A [m]	H [m]	P / W [kg]	
Torre inferior / Lower tower / Tour inférieure / Нижняя башня Alt kule / البرج السفلي	T16-90		6,146	2,085	2,085	2500
	T16-150		6,175	2,190	2,190	3535
Torre / Tower / Tour Башня / Kule / برج	T3-90		3,190	1,818	1,818	1200
	T6-90		6,140	1,818	1,818	2250
	T6-150A		6,175	1,870	1,870	2760
	T6-150		6,175	1,870	1,870	2760
Torre asiento pista + base punta de torre + orientación Slewing table + tower head base + slewing mechanism Tour pivot + base du porte-flèche + mécanisme d'orientation Сиденье площадки + основание верхней секции башни + поворотный механизм Göbek +kule kafa bölümü tabanı+mekanizma برج وحدة الدوارن + قاعدة رأس البرج + آلية الدوران			3,390	2,060	2,150	3700
Punta de torre / Tower head / Porte-flèche верхняя секция башни / kulenin kafa bölümü / رأس البرج			6,090	1,915	1,930	1700
Conjunto asiento pista, punta de torre, orientación y elevación Slewing table assembly, tower head, slewing and hoisting mechanism Groupe pivot + porte-flèche + mécanisme d'orientation + de levage Сиденье площадки + верхняя секция башни + поворотный механизм + подъемный механизм Göbek +kulenin kafa bölümü+mekanizma+vinç kulesi مجموعة وحدة الدوارن + رأس البرج + آلية الدوران + آلية الرفع			8,370	2,615	2,720	5400
Tramo de pluma Jib section Tronçon de flèche Секция стрелы Вот bölümü أجزاء الذراع	P14-1R (I)		8,665	1,366	1,698	1030
	P14-2N (II)		10,160	1,226	1,630	1150
	P14-16R (III)		10,160	1,226	1,630	1140
	P14-4N (IV)		5,270	1,226	1,630	495
	P14-17N (V)		10,160	1,226	1,630	695
	P14-15N (VI)		10,160	1,226	1,550	695
	P14-6N (VII)		5,270	1,226	1,545	323
	P14-8N (VIII)		2,095	1,366	1,740	195
Polipasto / Hook assembly / Palan / Полупаст / Kanca takımı / بكرة	SR/DR		1,420	0,500	1,000	400
Tirante sostén pluma / Jib support tie / Tirant de fleche / Растяжка поддержки стрелы / Kol destek bağları / مشد دعامة الذراع	Largo / Long / Corto / Short		5,30	0,70	1,750	650
			4,90	0,445	1,750	450
Carro / Trolley / Chariot / Грузовая тележка / Şaryo / عربة	SR/DR		2,005	1,665	1,525	390
Contrapluma con plataformas / Counterjib with platforms Contre-flèche avec plateformes / Противовесная консоль с платформами / الذراع المقابل مع المنصة / Platformlu kuuyruk			11,950	1,490	0,709	2495
Soporte y elevación / Support and hoisting / Support et levage / Опора и подъем / Destek ve vinç kulesi / دعم ورفع	EC3360VF		2,655	2,315	1,750	2160
	EC4880		2,655	2,315	1,750	2480
	EC60100VF		2,655	2,315	1,750	2625
Plataforma y cabina / Platform and cabin / Plateforme et cabine Платформа и кабина / Platform ve kabin / منصة وكابينة			3,760	2,050	2,400	1280
Contrapeso / Counterweight / Contrepoids / Противовес / Denge ağırlığı / أوزان معاكسة	Grande / Big / Grand / Большой / Büyük / كبير		1,080	0,500	2,025	2360
	Pequeño / Small / Petit / Малый / Küçük / صغير		1,080	0,500	1,305	1500
Lastre / Ballast / Lest / Балласт / Alt ağırlık taşları / ثقل			3,800	0,580	1,500	6000
Estructura torre de montaje / Jacking cage structure / Structure de tour de montage / Структура монтажной башни / Kaldırma kafesi yapısı / هيكل برج التركيب	TM 6-150		10,320	2,420	2,310	3500

LASTRES INFERIORES / LOWER BALLASTS / LESTS INFÉRIEURS / НИЖНИЙ БАЛЛАСТ / ALT AĞIRLIK TAŞLARI / ثقل

J118.8

BNI 45-100	H (m)	19,2	31	36,9	42,7
	P (t)	36	48	60	72
BNI 6-150	H (m)	25	36,8	42,7	51,4
	P (t)	36	48	60	96

H: Altura bajo gancho / Height under hook / Hauteur maximale sous crochet Высота под крюком / Kanca alti yüksekliği / الارتفاع أسفل الخطاف
Para alturas intermedias tomar el lastre correspondiente a la altura superior / For intermediate heights take the ballast corresponding to the higher height / Pour les hauteurs intermédiaires, opter pour le lest correspondant à la hauteur immédiatement supérieure / Для промежуточных высот возьмите балласт, соответствующий большей высоте / Orta yükseklikler için daha üst bir yüksekliğe karşılık gelen ağırlığı alınız. / لارتفاعات البينية يرجى استخدام الثقل للعائد للارتفاع الأعلى / حقوق التغيير محفوظة دون إشعار مسبق. دون أدنى مسؤولية عن المعلومات المقدمة



Fecha / Date: 20/10/2016

 **FEM 1005 - C25**

Reservado el derecho a modificaciones sin previo aviso. Declinamos toda responsabilidad derivada de la información proporcionada / Subject to modification, without previous warning. This information is supplied without liability / L'entreprise se réserve le droit de procéder à des modifications sans préavis. Nous déclinons toute responsabilité quant aux informations fournies / Мы оставляем за собой право на внесение изменений без предварительного уведомления. Мы снимаем с себя любую ответственность в отношении предоставленной информации / Önceden bildirilmeksizin değiştirilme hakkı saklıdır. Verilen bilgiler için hiçbir sorumluluk kabul etmemekteyiz / حقوق التغيير محفوظة دون إشعار مسبق. دون أدنى مسؤولية عن المعلومات المقدمة

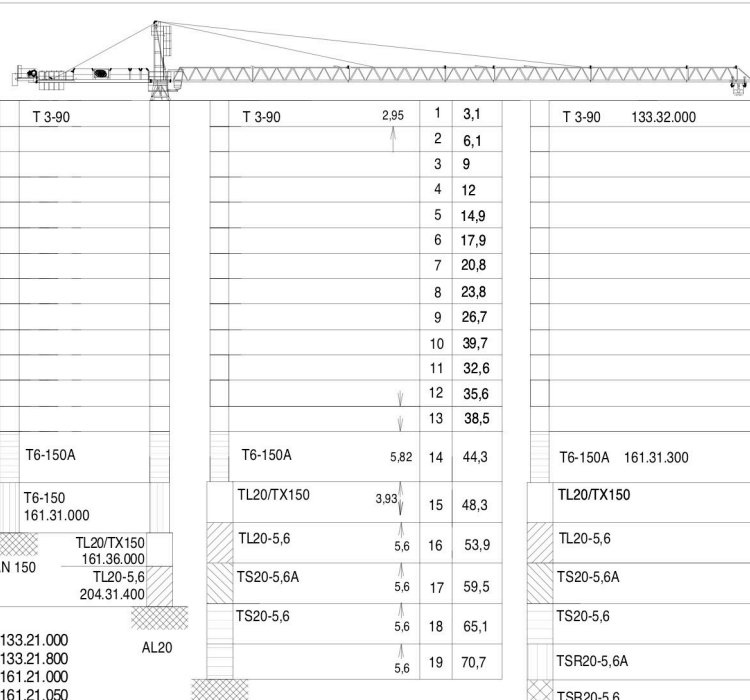

T	H					T	H
1	3,1		T 3-90			1	3,1
2	6,1					2	6,1
3	9					3	9
4	12					4	12
5	14,9					5	14,9
6	17,9					6	17,9
7	20,8					7	20,8
8	23,8					8	23,8
9	26,7					9	26,7
10	39,7					10	39,7
11	32,6					11	32,6
12	35,6					12	35,6
13	38,5					13	38,5
14	44,4		T6-150A			14	44,3
15	50,2		T6-150 161.31.000			15	48,3
16	54,1		TL20/TX150 161.36.000			16	53,9
17	59,7		AN 150 TL20-5,6 204.31.400			17	59,5
						18	65,1
						19	70,7
						20	76,3

AN 90 133.21.000
AND 90 133.21.800
AN 150 161.21.000
AND 150 161.21.050
AL 20 153.21.800
ALD 20 160.21.250
AS 20 160.21.010
ASD 20/24 160.21.080
ASR 20 160.21.200
ASRD 20/24 156.21.000

T: Torre / Tower / Tour / Башни / Kuleler / أبراج
H: Altura / Height / Hauteur / Высота / Yükseklik / ارتفاع

Otras configuraciones de torre / Other tower configuration / Autres configurations / Прочие конфигурации / Diğer konfigürasyonlar / مكونات أخرى

Transporte
Transport / Transport /
Транспортировка / Taşıma / نقل

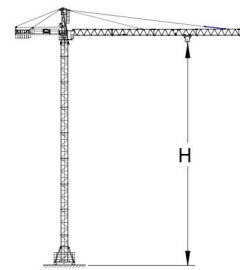

H=42,7; + BNI 45 100

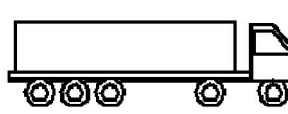

6x

7x HIGH CUBE 40'

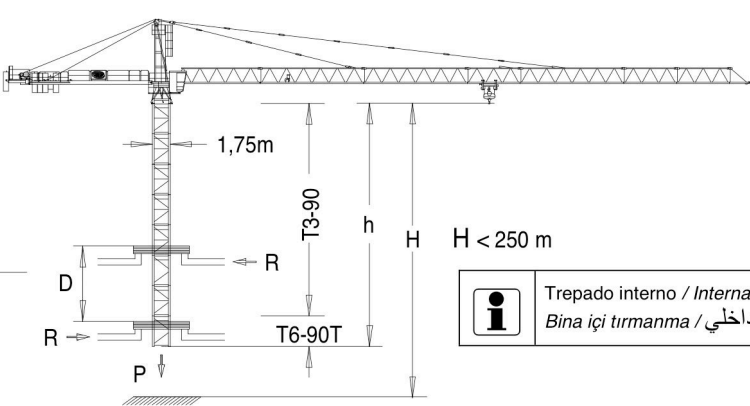

h_{max}: T6-90T + 11xT3-90

	▶	■
h (m)	39,1	
D (m)	15,8 - 20	
P (KN)	635	595
Rmax (KN)	99	200

T6-90T = 139.32.700

Trepado interno / Internal climbing. / Télescopage intérieur / Внутренняя лестница / Bina içi tırmanma / التسلق الداخلي

- ⚠ Viento fuera de servicio / Out of service wind / Vitesse du vent hors service / Ветровая нагрузка в покое / Rüzgar devre dışı / الريح خارج الخدمة
- ℹ Consultar / Consult / Nous consulter / Консультируемся / Danışınız / الرجوع إلى
- ▶ En servicio / In service / En service / В работе / Devrede / في الخدمة
- Fuera de servicio / Out of service / Hors service / В покое / Devre dışı / خارج الخدمة



LOC & MAT

FEM 1005 - C25

GSM: +33(0)6 11 16 84 14

E-mail: contact@locetmat.com
Web Site: www.locetmat.com

Tel: +33(0)4 68 92 50 92

Reservado el derecho a modificaciones sin previo aviso. Declinamos toda responsabilidad derivada de la información proporcionada / Subject to modification, without previous warning. This information is supplied without liability / L'entreprise se réserve le droit de procéder à des modifications sans préavis. Nous déclinons toute responsabilité quant aux informations fournies / Мы оставляем за собой право на внесение изменений без предварительного уведомления. Мы снимаем с себя любую ответственность в отношении предоставленной информации / Önceden bildirilmeksizin değiştirilme hakkı saklıdır. Verilen bilgiler için hiçbir sorumluluk kabul etmemekteyiz /

حقوق التغيير محفوظة دون إشعار مسبق. دون أدنى مسؤولية عن المعلومات المقدمة