

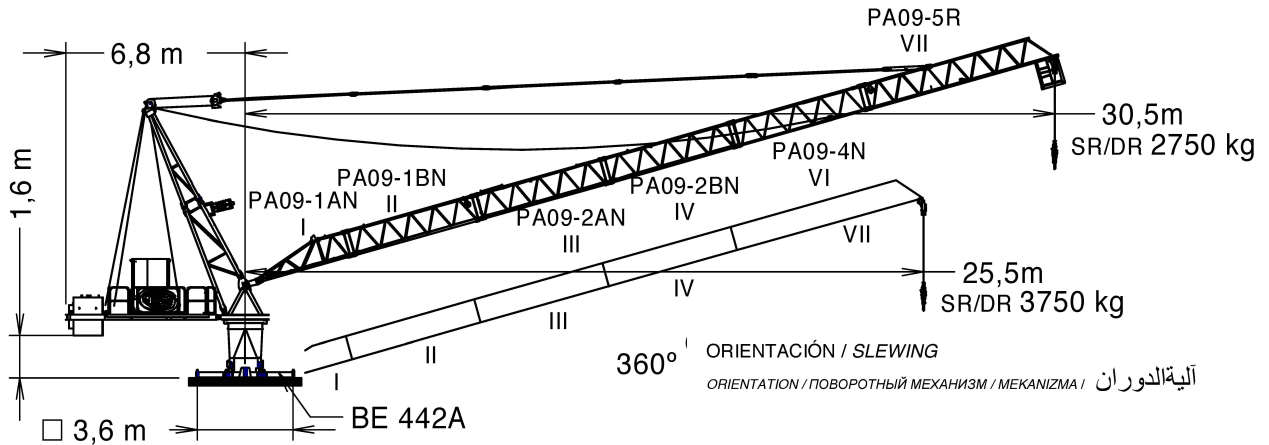

UNE 58-101
FEM 1001

UNE-EN-ISO 9001

RECOVERY CRANE:



$H_{SR} =$ Máxima altura de torre sin arriostrar (m). Maximum tower height without fastening (m). Hauteur maximale de tour sans ancrage (m). Максимальная высота башни без крепления (м). Desteksiz maksimum kule yüksekliği (m). أقصى ارتفاع للبرج بدون ربط (م)	PA09-1AN	202.40.300	TMU 1.18	202.35.500	
	PA09-1BN	202.40.400	TR 4R	202.32.000	
	PA09-2AN	202.41.300	TR 12RM	137.31.700	
	PA09-2BN	202.41.400	BE 442A	138.24.800	
	PA09-3N	202.42.000	BTX 45 / BEX 45	137.20.500	
	PA09-4N	202.43.000	BTX 38R / BEX 38R	137.20.000	
* Punta de pluma / Jib end / Pointe de flèche / Конец стрелы / Вот уcu / مقدمة الذراع /		PA09-5R	202.44.300	ABH 75	152.23.000
		Punta de pluma / Jib end*	202.45.800	AR 12	137.21.000

LUFFING CRANE:

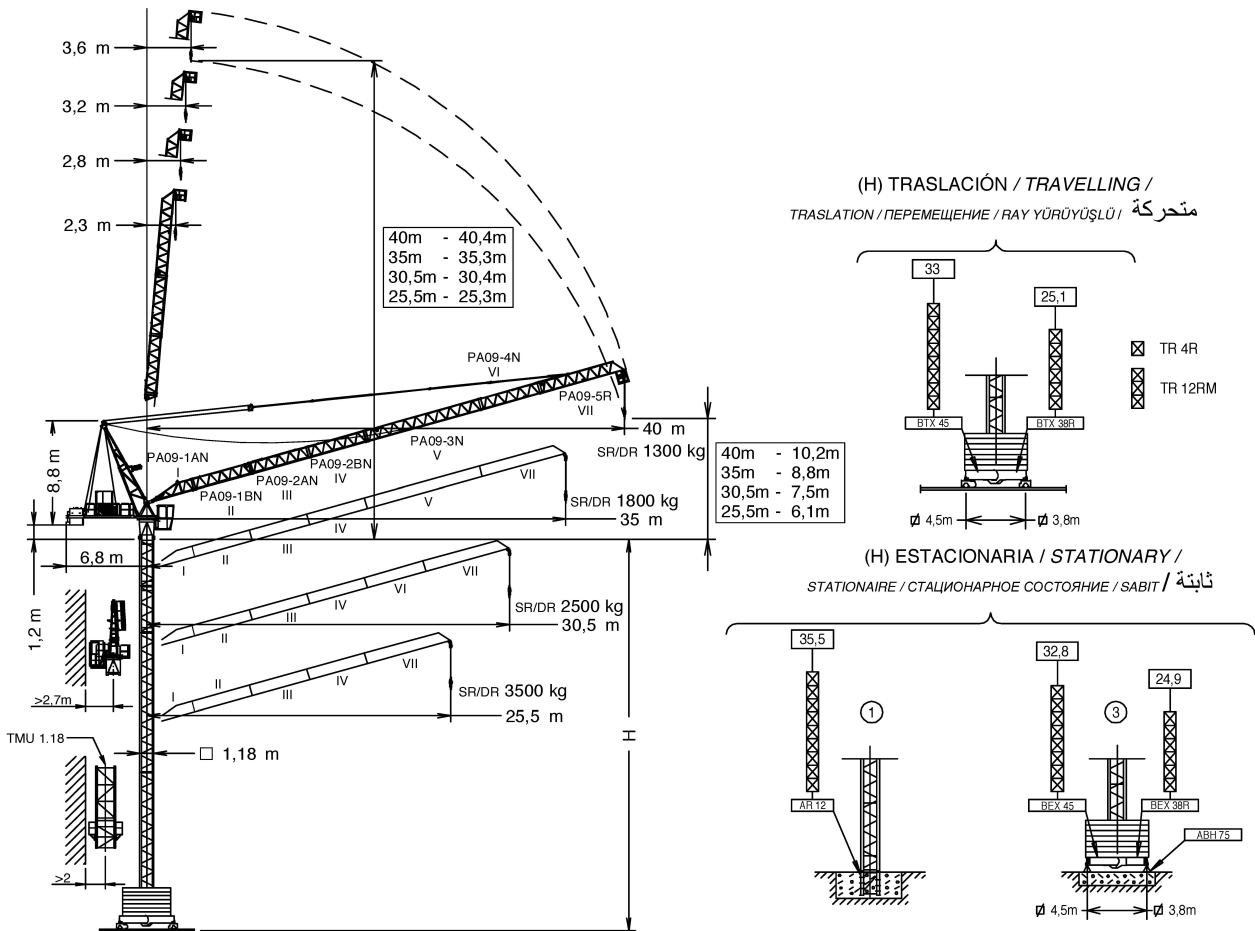

(H) TRASLACIÓN / TRAVELLING /
 TRASLACION / ПЕРЕМЕЩЕНИЕ / RAY YÜRÜYÜŞLÜ / متحركة

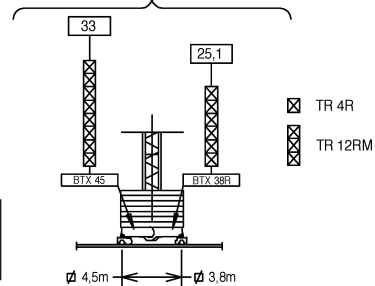

(H) ESTACIONARIA / STATIONARY /
 STATIONAIRE / СТАЦИОНАРНОЕ СОСТОЯНИЕ / SABIT / ثابتة

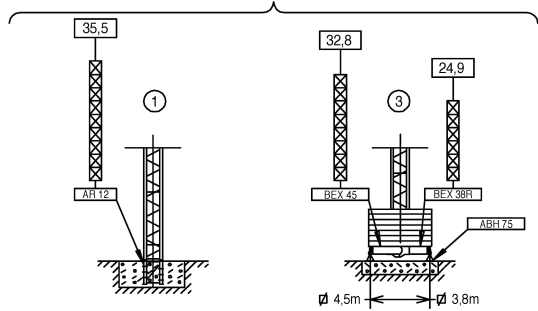



Fecha / Date: 08/04/2020





Reservado el derecho a modificaciones sin previo aviso. Declinamos toda responsabilidad derivada de la información proporcionada / Subject to modification, without previous warning. This information is supplied without liability / L'entreprise se réserve le droit de procéder à des modifications sans préavis. Nous déclinons toute responsabilité quant aux informations fournies / Мы оставляем за собой право на внесение изменений без предварительного уведомления. Мы снимаем с себя любую ответственность в отношении предоставленной информации / Önceden bildirilmeksizin değiştirilme hakkı saklıdır. Verilen bilgiler için hiçbir sorumluluk kabul etmemekteyiz. حقوق التغيير محفوظة دون إشعار مسبق. دون أدنى مسؤولية عن المعلومات المقدمة

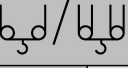

RECOVERY CRANE:



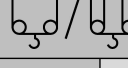



 SR / DR (kg)		Cargas máximas / Maximum loads / Charges maximales / Максимальные нагрузки / Maksimum yük / أقصى حمولة SR / DR- 4000 / 8000 kg			
 [m]	4000/8000 kg @ ... (m)	Alcance del gancho [m] / Hook reach [m] / Portée du crochet (m) / Радиус действия крюка (m) / Kancanın yüksekliği (m) / مدى الخطاف			
		15	20	25,5	30,5
30,5 m	23,9/14,0	4000/7350	4000/5100	3750	2750
25,5 m	24,4/14,2	4000/7460	4000/5220	3750	—

LUFFING CRANE:

 SR / DR (kg)		Cargas máximas / Maximum loads / Charges maximales / Максимальные нагрузки / Maksimum yük / أقصى حمولة SR / DR-2500 / 5000 kg				
 [m]	2500/5000 kg @ ... (m)	Alcance del gancho [m] / Hook reach [m] / Portée du crochet (m) / Радиус действия крюка (m) / Kancanın yüksekliği (m) / مدى الخطاف				
		20	25,5	30,5	35	40
40 m	29/18,3	2500/4400	2500/3150	2350	1750	1300
35 m	29,3/18,3	2500/4430	2500/3220	2400	1800	—
30,5 m	30,5/18,9	2500/4640	2500/3400	2500/2500	—	—
25,5 m	25,5/19,6	2500/4860	2500/3500	—	—	—

CARACTERISTICAS DE MECANISMOS / MECHANISMS FEATURES / CARACTÉRISTIQUES DES

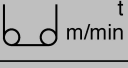
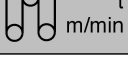
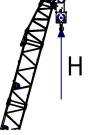
MÉCANISMES / ХАРАКТЕРИСТИКИ МЕХАНИЗМОВ / MEKANİZMALARIN ÖZELLİKLERİ / الخصائص الآلية

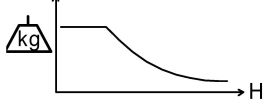
*opcional *optional *en option *опция *opsiyonel *اختياري						
	RECOVERY CRANE EC4076VF 29,4 kW	LUFFING CRANE EC4076VF 29,4 kW	☑ 2,8 / 3,8 / 4,5 m TG825VF 2x3 kW	OG608VF 4 kW	EP2515VF 18,4 kW	TH1010 9,2 kW
 m/min	2 4 0...76 0...38	2 2,5 0...76 0...60	0...25 m/min	0...0,8 r/min sl/min	1,5 min	1 m/min
 m/min	4 8 0...38 0...19	2,5 5 0...38 0...30				
	H ≤ SR 800 m DR 400 m	⚡ 400V 50Hz P_{TOTAL} (EC4076VF + OG608VF + EP2515VF) = 51,8 kW				
						

LASTRES INFERIORES / LOWER BALLASTS

LESTS INFÉRIEURS / НИЖНИЙ БАЛЛАСТ / ALT AĞIRLIK TAŞLARI / ثقُل

H (m)		9,3	17,2	25,1	33
BEX 45 / BTX 45	 4100 kg	8	10	12	14
BEX 38R / BTX 38R		10	12	14	—

H: Altura bajo gancho / Height under hook / Hauteur maximale sous crochet / Высота под крюком / Kanca altı yüksekliği / الارتفاع أسفل الخطاف



Para alturas intermedias tomar el lastre correspondiente a la altura superior / For intermediate heights take the ballast corresponding to the higher height / Pour les hauteurs intermédiaires, opter pour le lest correspondant à la hauteur immédiatement supérieure / Для промежуточных высот возьмите балласт, соответствующий большей высоте / Orta yükseklikler için daha üst bir yüksekliğe karşılık gelen ağırlığı alınız. / حقوق التغيير محفوظة دون إشعار مسبق. دون أدنى مسؤولية عن المعلومات المقدمة

Fecha / Date: 08/04/2020

FEM 1001

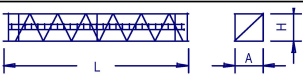
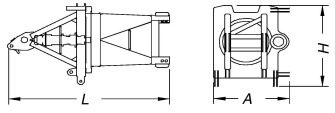
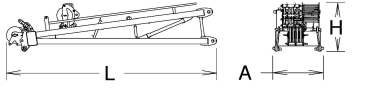
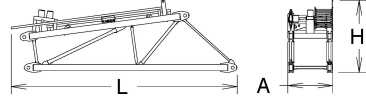
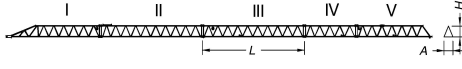
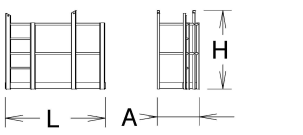
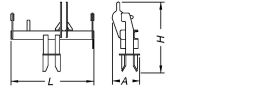
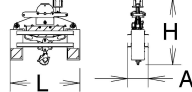
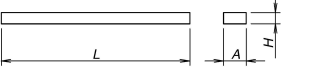
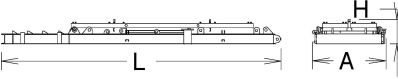
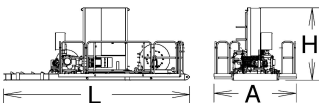
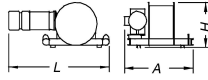
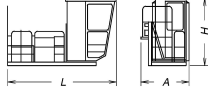

Reservado el derecho a modificaciones sin previo aviso. Declinamos toda responsabilidad derivada de la información proporcionada / Subject to modification, without previous warning. This information is supplied without liability / L'entreprise se réserve le droit de procéder à des modifications sans préavis. Nous déclinons toute responsabilité quant aux informations fournies / Мы оставляем за собой право на внесение изменений без предварительного уведомления. Мы снимаем с себя любую ответственность в отношении предоставленной информации / Önceden bildirilmeksizin değiştirilme hakkı saklıdır. Verilen bilgiler için hiçbir sorumluluk kabul etmemekteyiz / حقوق التغيير محفوظة دون إشعار مسبق. دون أدنى مسؤولية عن المعلومات المقدمة

DENOMINACIÓN / DENOMINATION / DÉSIGNATION / НАЗВАНИЕ / AÇIKLAMA / اسم		L [m]	A [m]	H [m]	P / W [kg]	
Torre / Tower / Tour Башня / Kule / برج	TR 8RM TR 12RM TR 4R		8,07 12,01 4,15	1,19 1,19 1,19	2575 3715 1430	
Torre asiento pista + base punta de torre + orientación Slewing table + tower head base + slewing mechanism Tour pivot + base du porte-flèche + mécanisme d'orientation Сиденье площадки + основание верхней секции башни + поворотный механизм Göbek +kule kafa bölümü tabanı+mekanizma برج وحدة الدوارن + قاعدة رأس البرج + آلية الدوران		3,413	1,609	1,950	2390	
Punta de torre 1 / Tower head / Porte-flèche верхняя секция башни / kulenin kafa bölümü / رأس البرج		4,430	1,067	1,026	940	
Punta de torre 2 / Tower head / Porte-flèche верхняя секция башни / kulenin kafa bölümü / رأس البرج		4,533	0,900	1,450	845	
Tramo de pluma Jib section Tronçon de flèche Секция стрелы Вот bölümü أجزاء الذراع	PA09-1AN (I) PA09-1BN (II) PA09-2AN (III) PA09-2BN (IV) PA09-3N (V) PA09-4N (VI) PA09-5R (VII)		3,975 5,220 5,225 5,220 10,115 5,220 7,470	1,025 0,860 0,860 0,860 0,860 0,860 0,865	1,205 1,030 1,050 1,050 1,065 1,065 1,180	453 360 373 294 530 276 560
Plataforma de punta de pluma Jib end platform Plateforme de pointe de flèche Платформа конца стрелы Вот уcu platformu منصة رأس الريشة		1,716	0,719	1,346	72	
Punta de pluma / Jib end / Pointe de flèche / Конец стрелы / Вот уcu / مقدمة الذراع		0,81	0,266	0,679	88	
Polipasto / Hook assembly / Palan / Полуснаст / Kanca takımı / بكرة		1,265	0,375	1,214	740	
Tirante sostén pluma / Jib support tie / Tirant de fleche / Растяжка поддержки стрелы / Kol destek bağları / مشد دعامة الذراع		5,1	0,36	0,3	285	
Contrapluma con plataformas / Counterjib with platforms Contre-flèche avec plateformes / Противовесная консоль с платформами / Platformlu kuyruk / الذراع المقابل مع المنصة		5,595	2,565	0,245	800	
Contrapluma con plataformas, armario eléctrico y mecanismos Counterjib with platforms, electric control cupboard and mechanisms Contre-flèche avec plateformes, armoire électrique et mécanismes		5,830	2,571	2,270	3995	
Mecanismos Mechanisms Mécanismes de	Elevación carga / Hoisting / levage de charge / Подъем груза / Yük kaldırma / رافع الحمولة Elevación pluma / Luffing / Relevage de flèche /		1,93 1,9	1,318 1,247	0,845 0,758	1185 901
Plataforma y cabina / Platform and cabin / Plateforme et cabine Платформа и кабина / Platform ve kabin / منصة وكابينة		3,759	1,65	2,338	820	
Lastre / Ballast / Lest / Балласт / Alt ağırlık taşları / ثقل		4,00	0,34	1,30	4100	
Torre de montaje / Jacking cage Tour de montage / Монтажная башня / Kaldırma kafesi / برج التركيب	TMU 1.18	7,14	1,76	1,71	3200	
Torre de montaje sin puerta, carro, plataforma carro y viga de apoyo Jacking cage without door, trolley, trolley platform and beam assembly Tour de montage sans porte, chariot, plateforme de chariot et poutre de soutien		7,14	1,76	1,71	2450	

