

GMR HD 21 A

Courbes de charges - Lastkurven - Load diagrams - Curvas de cargas - Curve di carico

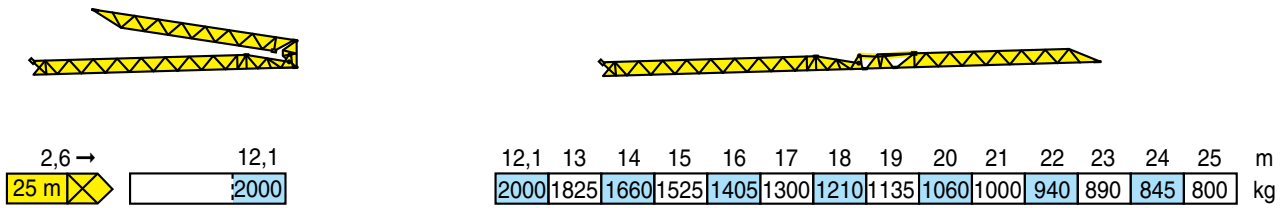

Flèche relevée - Ausleger in Steilstellung - Luffing jib - Flecha izada - Braccio impennato

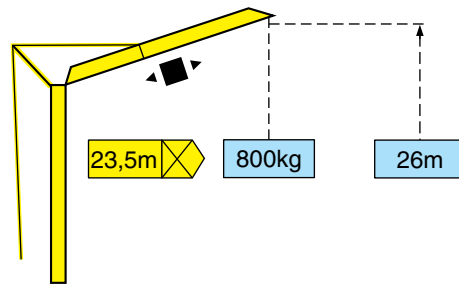

2 D2 V4



Chariot distributeur
Verfahrbare Laufkatze
Traversing trolley
Carro distribuidor
Carrellino distributore

Réaction - Eckdrücke - Reactions - Reacciones - Reazioni

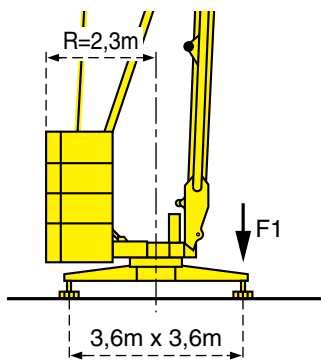

F1 (R=2,3m)	● 12,3t	■ 6,8t
----------------	---------	--------

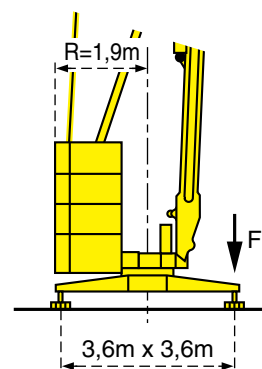

F1 (R=1,9m)	● 13,4t	■ 7,9t
----------------	---------	--------

⊗	7,4t
---	------

● En service
■ Hors service

● In Betrieb
■ Ausser Betrieb

● In service
■ Out of service

● En servicio
■ Fuera de servicio

● In servizio
■ Fuori servizio

⊗ A vide sans lest ni train de transport avec flèche et hauteur maximum.







⊗ Ohne Last, Ballast und Transportachse, mit Maximalausleger und Maximalhöhe.

⊗ Without load, ballast or transport axles, with maximum jib and maximum height.

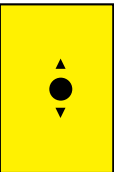
⊗ Sin carga, sin lastre, ni tren de transporte, flecha y altura máximas.

⊗ A vuoto, senza zavorra ne assali di trasporto con braccio massimo e altezza massima.

Mécanismes - Antriebe - Mechanisms - Mecanismos - Meccanismi

				m/min	Kg	ch -PS hp	kW
Levage Heben Hoisting Elevación Sollevamento		9 PC 10	  	6,6 20 40	2000 2000 1000	8,2	6
Distribution - <i>Katzfahren</i> - Trolleying Distribución - Distribuzione		2 D2 V4		18 - 36		2	1,5
Orientation - <i>Schwenken</i> - Slewing Orientación - Rotazione		RCO 11		0 → 0,3 - 0,9 tr/min - U/min - rpm		1,5	1,1
Réseau - <i>Netzstrom</i> - Mains supply - <i>Red</i> - Rete elettrica						380V.50Hz	
Puissance électrique nécessaire - <i>Anschlusswert</i> - Necessary electric power Potencia eléctrica necesaria - Potenza elettrica necessaria						12 kVA	
Groupe électrogène - <i>Stromaggregat</i> - Generator set - <i>Grupo electrogeno</i> - Gruppo elettrogeno						*	

*Nous consulter - *Auf Anfrage* - Consult us - *Consultarnos* - Consultateci

Conforme à la directive CEE 84/534 sur le niveau acoustique - *Gemäss EWG-Richtlinie 84/534 Schall- Leistungspegel*
 In compliance with the EEC 84/534 Instruction on noise level - *Conforme con la direttiva CEE 84/534 sobre el nivel acustico*
 Conforme colla direttiva CEE 84/534 sul livello acustico

Montage - Montage - Erection - Montaje - Montaggio

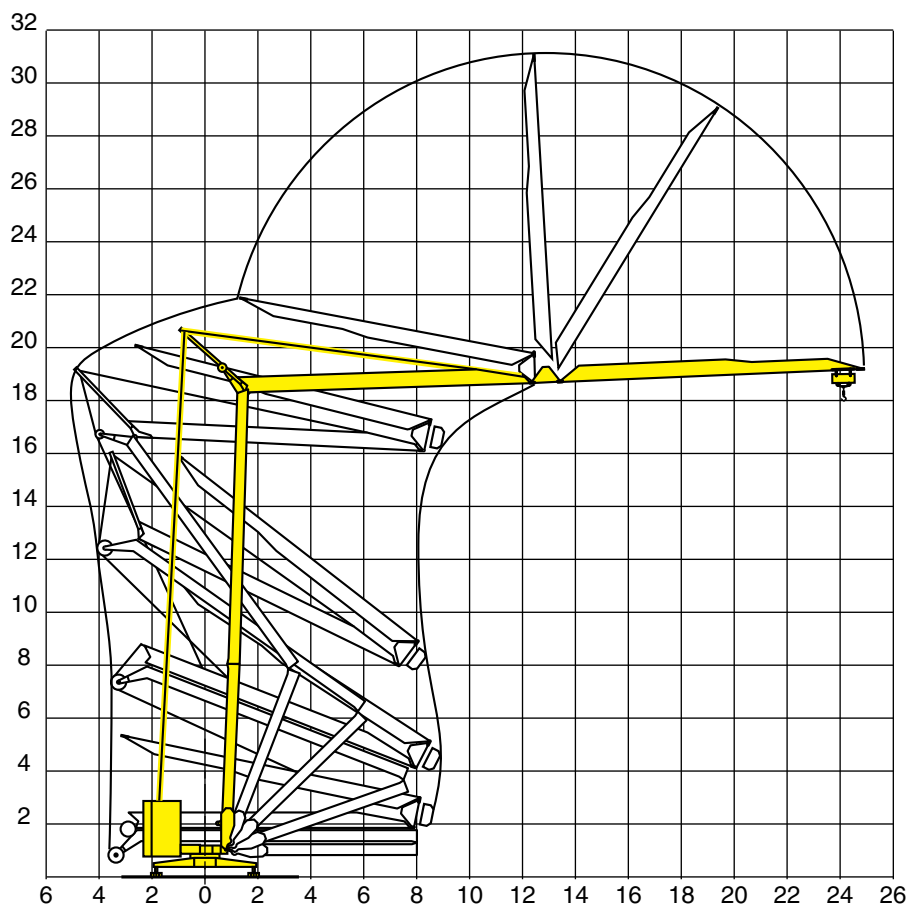

Transport - Transport - Transport - Transporte - Trasporto

- 18/27
- 15A/25A
- 14A/21A

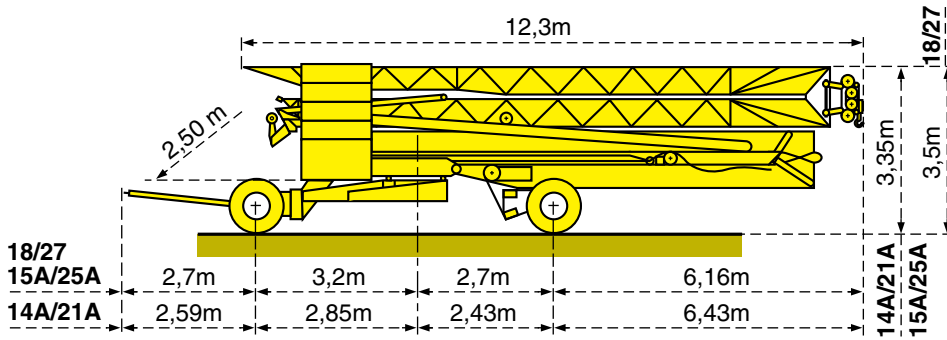

- DJ125/S105
- DS60/S105
- DS60/S80
- DS51/S70

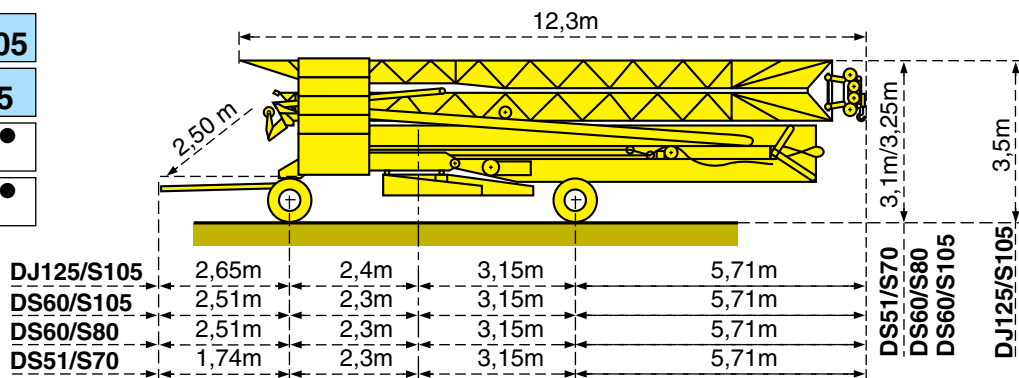

- Chantier
- Baustelle
- Site
- Obra
- Cantiere



NF E 52081 - 82
DIN 15018.H1 B3

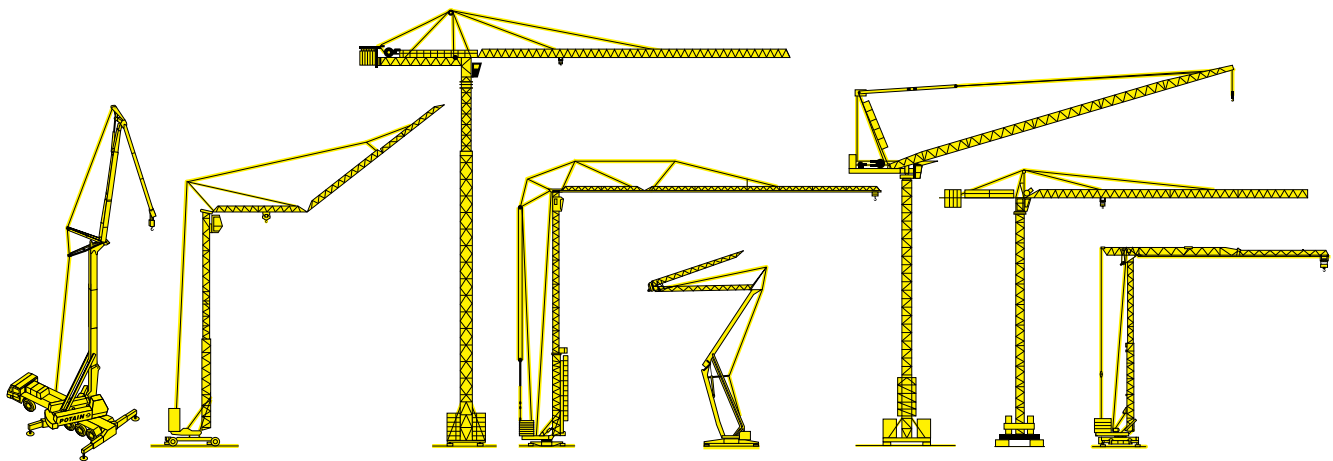

Document pour usage commercial uniquement - Benutzung dieser Unterlagen nur für Verkaufszwecke - Document for commercial use only - Documento para uso comercial unicamente - Documento para uso commerciale solamente

Copyright.Reproduction interdite © POTAIN 1992



18.Rue de Charbonnières, B.P. 173-F 69132 ECULLY Cedex
Tél. 72.20.20.20 - Télex 375 213 - Fax 72.20.20.00
POTAIN GmbH Deutschland Tel : 06.105.704.0
POTAIN U.K. Great Britain Tel : 0895.44.52.61
Simma POTAIN Italia Tel : 02.97.96.71
POTAIN Portugal Portugal Tel : 02.968.08.89

GMR HD 21 A

Réf. 1992.38 LFK 6